

# RECHERCHE COOPÉRATIVE SUR PROGRAMME N° 25

DAVID RUELLE

FLORIS TAKENS

## **On the Nature of Turbulence**

*Les rencontres physiciens-mathématiciens de Strasbourg - RCP25, 1971, tome 12*  
« Conférences de H. Brézis, D. Ruelle et F. Takens et un texte de R. Gérard et Mme A. Sec », , exp. n° 2, p. 1-44

[http://www.numdam.org/item?id=RCP25\\_1971\\_\\_12\\_\\_A2\\_0](http://www.numdam.org/item?id=RCP25_1971__12__A2_0)

© Université Louis Pasteur (Strasbourg), 1971, tous droits réservés.

L'accès aux archives de la série « Recherche Coopérative sur Programme n° 25 » implique l'accord avec les conditions générales d'utilisation (<http://www.numdam.org/conditions>). Toute utilisation commerciale ou impression systématique est constitutive d'une infraction pénale. Toute copie ou impression de ce fichier doit contenir la présente mention de copyright.

NUMDAM

Article numérisé dans le cadre du programme  
Numérisation de documents anciens mathématiques  
<http://www.numdam.org/>

ON THE NATURE OF TURBULENCE

David RUELLE

and

Floris TAKENS \*)

I. H. E. S.

91. BURES-sur-YVETTE. FRANCE

Abstract. A mechanism for the generation of turbulence and related phenomena in dissipative systems is proposed.

\*) The research was supported by the Netherlands Organisation for the Advancement of Pure Research (Z.W.O.)

§ 1 Introduction.

If a physical system consisting of a viscous fluid (and rigid bodies) is not subjected to any external action, it will tend to a state of rest (equilibrium). We submit now the system to a steady action (pumping, heating, etc.) measured by a parameter  $\mu$  <sup>\*)</sup>. When  $\mu = 0$  the fluid is at rest. For  $\mu > 0$  we obtain first a steady state, i.e., the physical parameters describing the fluid at any point (velocity, temperature, etc.) are constant in time, but the fluid is no longer in equilibrium. This steady situation prevails for small values of  $\mu$ . When  $\mu$  is increased various new phenomena occur; (a) the fluid motion may remain steady but change its symmetry pattern; (b) the fluid motion may become periodic in time; (c) for sufficiently large  $\mu$ , the fluid motion becomes very complicated, irregular and chaotic, we have turbulence.

The physical phenomenon of turbulent fluid motion has received various mathematical interpretations. It has been argued by Leray [9] that it leads to a breakdown of the validity of the equations (Navier-Stokes) used to describe the system. While such a breakdown may happen we think that it does not necessarily accompany turbulence. Landau and Lifschitz [8] propose that the physical parameters  $x$  describing a fluid in turbulent motion are quasi-periodic functions of time:

$$x(t) = f(\omega_1 t, \dots, \omega_k t)$$

---

\*) Depending upon the situation,  $\mu$  will be the Reynolds number, Rayleigh number, etc.

where  $f$  has period 1 in each of its arguments separately and the frequencies  $\omega_1, \dots, \omega_k$  are not rationally related<sup>†)</sup>. It is expected that  $k$  becomes large for large  $\mu$ , and that this leads to the complicated and irregular behaviour characteristic of turbulent motion. We shall see however that a dissipative system like a viscous fluid will not in general have quasi-periodic motions<sup>\*)</sup>. The idea of Landau and Lifschitz must therefore be modified.

Consider for definiteness a viscous incompressible fluid occupying a region  $D$  of  $\mathbb{R}^3$ . If thermal effects can be ignored, the fluid is described by its velocity at every point of  $D$ . Let  $H$  be the space of velocity fields  $v$  over  $D$ ;  $H$  is an infinite dimensional vector space. The time evolution of a velocity field is given by the Navier-Stokes equations

$$\frac{dv}{dt} = X_\mu(v) \quad (1)$$

where  $X_\mu$  is a vector field over  $H$ . For our present purposes it is not necessary to specify further  $H$  or  $X_\mu$ <sup>\*\*)</sup>.

---

\*) Quasi-periodic motions occur for other systems, see Moser [10].

\*\*\*) A general existence and uniqueness theorem has not been proved for solutions of the Navier-Stokes equations. We assume however that we have existence and uniqueness locally, i.e., in a neighbourhood of some  $v_0 \in H$  and of some time  $t_0$ .

†) This behaviour is actually found and discussed by E. Hopf in a model of turbulence [A Mathematical Example Displaying Features of Turbulence, Comm. Pure Applied Math. 303-322 (1948)].

In what follows we shall investigate the nature of the solutions of (1), making only assumptions of a very general nature on  $X_{\mu}$ . It will turn out that the fluid motion is expected to become chaotic when  $\mu$  increases. This gives a justification for turbulence and some insight into its meaning. To study (1) we shall replace  $H$  by a finite-dimensional manifold<sup>\*)</sup> and use the qualitative theory of differential equations.

For  $\mu = 0$ , every solution  $v(\cdot)$  of (1) tends to the solution  $v_c = 0$  as the time tends to  $+\infty$ . For  $\mu > 0$  we know very little about the vector field  $X_{\mu}$ . Therefore it is reasonable to study generic deformations from the situation at  $\mu = 0$ . In other words we shall ignore possibilities of deformation which are in some sense exceptional. This point of view could lead to serious error if, by some law of nature which we have overlooked,  $X_{\mu}$  happens to be in a special class with exceptional properties<sup>\*\*)</sup>. It appears however that a three-dimensional viscous fluid conforms to the pattern of generic behaviour which we discuss below. Our discussion should in fact apply to very general dissipative systems<sup>\*\*\*)</sup>.

---

<sup>\*)</sup> This replacement can in several cases be justified, see § 5.

<sup>\*\*)</sup> For instance the differential equations describing a Hamiltonian (conservative) system, have very special properties. The properties of a conservative system are indeed very different from the properties of a dissipative system (like a viscous fluid). If a viscous fluid is observed in an experimental setup which has a certain symmetry, it is important to take into account the invariance of  $X_{\mu}$  under the corresponding symmetry group. This problem will be considered elsewhere.

<sup>\*\*\*)</sup> In the discussion of more specific properties, the behaviour of a viscous fluid may turn out to be nongeneric, due for instance to the local nature of the differential operator in the Navier-Stokes equations.

The present paper is divided into two chapters. Chapter I is oriented towards physics and is relatively untechnical. In Section 2 we review some results on differential equations; in Sections 3-4 we apply these results to the study of the solutions of (1). Chapter II contains the proofs of several theorems used in chapter I. In Section 5, center-manifold theory is used to replace  $H$  by a finite-dimensional manifold. In Sections 6-8 the theory of Hopf bifurcation is presented both for vector fields and for diffeomorphisms. In Section 9 an example of "turbulent" attractor is presented.

Acknowledgements.

The authors take pleasure in thanking R. Thom for valuable discussion, in particular introducing one of us (F.T.) to the Hopf bifurcation. Some inspiration for the present paper was derived from Thom's forthcoming book [12].

Chapter I.

§ 2. Qualitative theory of differential equations.

Let  $B = \{x : |x| < R\}$  be an open ball in the finite dimensional euclidean space  $H$  <sup>\*)</sup>. Let  $X$  be a vector field with continuous

derivatives up to order  $r$  on  $\bar{B} = \{x : |x| \leq R\}$ ,  $r$  fixed  $\geq 1$ .

These vector fields form a Banach space  $\mathcal{B}$  with the norm

$$\|X\| = \sup_{1 \leq i \leq \nu} \sup_{|\rho| \leq r} \sup_{x \in \bar{B}} \left| \frac{\partial |\rho|}{\partial x^\rho} X^i(x) \right|$$

where

$$\frac{\partial |\rho|}{\partial x^\rho} = \left( \frac{\partial}{\partial x^1} \right)^{\rho_1} \dots \left( \frac{\partial}{\partial x^\nu} \right)^{\rho_\nu}$$

and  $|\rho| = \rho_1 + \dots + \rho_\nu$ . A subset  $E$  of  $\mathcal{B}$  is called residual if it contains a countable intersection of open sets which are dense in  $\mathcal{B}$ .

Baire's theorem implies that a residual set is again dense in  $\mathcal{B}$ ; therefore a residual set  $E$  may be considered in some sense as a "large" subset of  $\mathcal{B}$ . A property of a vector field  $X \in \mathcal{B}$  which holds on a residual set of  $\mathcal{B}$  is called generic.

The integral curve  $x(\cdot)$  through  $x_0 \in B$  satisfies  $x(0) = x_0$  and  $d x(t)/dt = X(x(t))$ ; it is defined at least for sufficiently small  $|t|$ . The dependence of  $x(\cdot)$  on  $x_0$  is expressed by writing

---

\*) More generally we could use a manifold  $H$  of class  $C^r$ .

$x(t) = \Phi_{X,t}(x_0)$  ;  $\Phi_{X,t}$  is called integral of the vector field  $X$  ;  $\Phi_{X,1}$  is the time one integral. If  $x(t) \equiv x_0$  , i.e.  $X(x_0) = 0$  , we have a fixed point of  $X$  . If  $x(\tau) = x_0$  and  $x(t) \neq x_0$  for  $0 < t < \tau$  we have a closed orbit of period  $\tau$  . A natural generalization of the idea of closed orbit is that of quasi-periodic motion:

$$x(t) = f(\omega_1 t, \dots, \omega_k t)$$

where  $f$  is periodic of period 1 in each of its arguments separately and the frequencies  $\omega_1, \dots, \omega_k$  are not rationally related. We assume that  $f$  is a  $C^k$ -function and its image a  $k$ -dimensional torus  $T^k$  imbedded in  $B$  . Then however we find that a quasi-periodic motion is nongeneric. In particular for  $k = 2$  , Peixoto's theorem <sup>\*)</sup> shows that quasi-periodic motions on a torus are in the complement of a dense open subset  $\Sigma$  of the Banach space of  $C^1$  vector fields on the torus:  $\Sigma$  consists of vector fields for which the non wandering set  $\Omega$  <sup>\*\*)</sup>  is composed of a finite number of fixed points and closed orbits only.

As  $t \rightarrow +\infty$  , an integral curve  $x(t)$  of the vector field  $X$  may be attracted by a fixed point or a closed orbit of the vector field, or by a more general attractor <sup>\*\*\*)</sup> . It will probably not be attracted by

<sup>\*)</sup> See Abraham [1].

<sup>\*\*)</sup>  A point  $x$  belongs to  $\Omega$  (i.e. is non wandering) if for every neighbourhood  $U$  of  $x$  and every  $T > 0$  one can find  $t > T$  such that  $\Phi_{X,t}(U) \cap U \neq \emptyset$  . For a quasi-periodic motion on  $T^k$  we have  $\Omega = T^k$  .

<sup>\*\*\*)</sup> A closed subset  $A$  of the non wandering set  $\Omega$  is an attractor if it has a neighbourhood  $U$  such that  $\bigcap_{t > 0} \Phi_{X,t}(U) = A$  . For more attractors than those described here see Williams [13].



a quasi-periodic motion because these are rare. It is however possible that the orbit be attracted by a set which is not a manifold. To visualize such a situation in  $n$  dimensions, imagine that the integral curves of the vector field go roughly parallel and intersect transversally some piece of  $n-1$ -dimensional surface  $S$  (Fig.1).

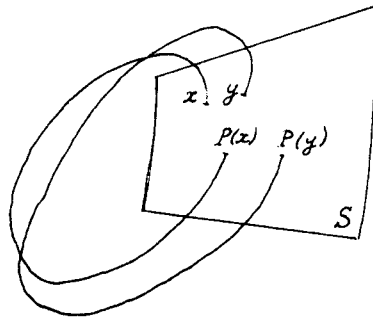

Fig. 1.

We let  $P(x)$  be the first intersection of the integral curve through  $x$  with  $S$  ( $P$  is a Poincaré map).

Take now  $n-1 = 3$ , and assume that  $P$  maps the solid torus  $\Pi_0$  into itself as shown in Fig. 2,

$$P \Pi_0 = \Pi_1 \subset \Pi_0$$

The set  $\bigcap_{n > 0} P^n \Pi_0$  is an attractor; it is locally the product of a Cantor set and a line interval (see Smale [11], Section I.9).

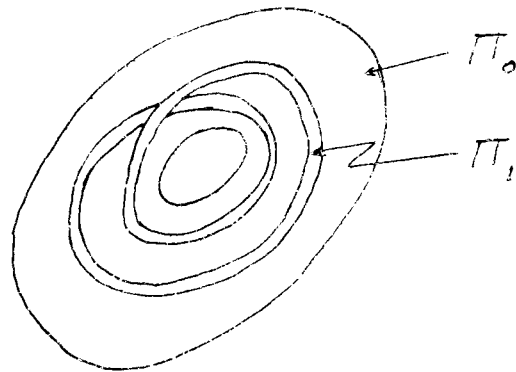

Fig. 2.

Going back to the vector field  $X$ , we have thus a "strange" attractor which is locally the product of a Cantor set and a piece of two-dimensional manifold. Notice that we keep the same picture if  $X$  is replaced by a vector field  $Y$  which is sufficiently close to  $X$  in the appropriate Banach space. An attractor of the type just described can therefore not be thrown away as non-generic pathology.

§ 3. A mathematical mechanism for turbulence.

Let  $X_\mu$  be a vector field depending on a parameter  $\mu$  \*)

The assumptions are the same as in Section 2, but the interpretation we have in mind is that  $X_\mu$  is the right-hand side of the Navier-Stokes equations. When  $\mu$  varies the vector field  $X_\mu$  may change in a number of manners. Here we shall describe a pattern of changes which is physically acceptable, and show that it leads to something like turbulence.

For  $\mu = 0$ , the equation

$$\frac{dx}{dt} = X_\mu(x)$$

has the solution  $x=0$ . We assume that the eigenvalues of the Jacobian matrix  $A^j_k$  defined by

$$A^j_k = \frac{\partial X^j_0}{\partial x^k}(0)$$

have all strictly negative real parts; this corresponds to the fact that the fixed point 0 is attracting. The Jacobian determinant is not zero and therefore there exists (by the implicit function theorem)  $\xi(\mu)$  depending continuously on  $\mu$  and such that

$$X_\mu(\xi(\mu)) = 0$$

---

\*)To be definite, let  $(x, \mu) \rightarrow X_\mu(x)$  be of class  $C^r$ .

In the hydrodynamical picture,  $\xi(\mu)$  describes a steady state.

We follow now  $\xi(\mu)$  as  $\mu$  increases. For sufficiently small  $\mu$  the Jakobian matrix  $A_k^j(\mu)$  defined by

$$A_k^j(\mu) = \frac{\partial X_\mu^j}{\partial x^k}(\xi(\mu)) \quad (2)$$

has only eigenvalues with strictly negative real parts (by continuity). We assume that, as  $\mu$  increases, successive pairs of complex conjugate eigenvalues of (2) cross the imaginary axis, for  $\mu = \mu_1, \mu_2, \mu_3, \dots$  <sup>\*)</sup>. For  $\mu > \mu_1$ , the fixed point  $\xi(\mu)$  is no longer attracting. It has been shown by E. Hopf <sup>\*\*)</sup> that when a pair of complex conjugate eigenvalues of (2) cross the imaginary axis at  $\mu_1$ , there is a one-parameter family of closed orbits of the vector field in a neighbourhood of  $(\xi(\mu_1), \mu_1)$ . More precisely there are continuous functions  $y(\omega)$ ,  $\mu(\omega)$  defined for  $0 \leq \omega < 1$  such that

(a)  $y(0) = \xi(\mu_1)$ ,  $\mu(0) = \mu_1$

(b) the integral curve of  $X_{\mu(\omega)}$  through  $y(\omega)$  is a closed orbit for  $\omega > 0$ .

Generically  $\mu(\omega) > \mu_1$  or  $\mu(\omega) < \mu_1$  for  $\omega \neq 0$ . To see how the

\*) Another less interesting possibility is that a real eigenvalue vanishes. When this happens the fixed point  $\xi(\lambda)$  generically coalesces with another fixed point and disappears (this generic behaviour is changed if some symmetry is imposed to the vector field  $X_\mu$ ).

\*\*\*) Hopf [6] assumes that  $X$  is real-analytic; the differentiable case is treated in Section 6 of the present paper.

closed orbits are obtained we look at the two-dimensional situation in a neighbourhood of  $\xi(\mu_1)$  for  $\mu < \mu_1$  (Fig. 3) and  $\mu > \mu_1$  (Fig. 4).



Fig. 3.

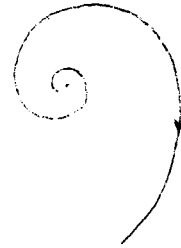

Fig. 4.

Suppose that when  $\mu$  crosses  $\mu_1$  the vector field remains like that of Fig. 3 at large distances of  $\xi(\mu)$ ; we get a closed orbit as shown in Fig. 5.

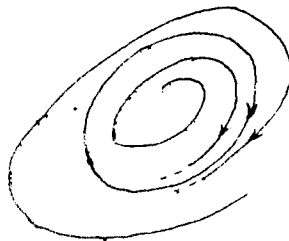

Fig. 5.

Notice that Fig. 4 corresponds to  $\mu > \mu_1$  and that the closed orbit is attracting. Generally we shall assume that the closed orbits appear for  $\mu > \mu_1$  so that the vector field at large distances of  $\xi(\mu)$  remains attracting in accordance with physics. As  $\mu$  crosses  $\mu_1$  we have then replacement of an attracting fixed point by an attracting closed orbit. The closed orbit is physically interpreted as a periodic motion, its amplitude increases with  $\mu$ .

§ 3. a. Study of a nearly split situation

To see what happens when  $\mu$  crosses the successive  $\mu_i$ , we let  $E_i$  be the two-dimensional linear space associated with the  $i$ -th pair of eigenvalues of the Jacobian matrix. In first approximation the vector field  $X_\mu$  is, near  $\mu_i$ , of the form

$$\tilde{X}_\mu(x) = \tilde{X}_{\mu-1}(x_1) + \tilde{X}_{\mu-2}(x_2) + \dots \quad (3)$$

where  $\tilde{X}_{\mu-i}$ ,  $x_i$  are the components of  $\tilde{X}_\mu$  and  $x$  in  $E_i$ . If  $\mu$  is in the interval  $(\mu_k, \mu_{k+1})$ , the vector field  $\tilde{X}_\mu$  leaves invariant a set  $\tilde{T}^k$  which is the cartesian product of  $k$  attracting closed orbits  $\Gamma_1, \dots, \Gamma_k$  in the spaces  $E_1, \dots, E_k$ . By suitable choice of coordinates on  $\tilde{T}^k$  we find that the motion defined by the vector field on  $\tilde{T}^k$  is quasi-periodic (the frequencies  $\tilde{\omega}_1, \dots, \tilde{\omega}_k$  of the closed orbits in  $E_1, \dots, E_k$  are in general not rationally related).

Replacing  $\tilde{X}_\mu$  by  $X_\mu$  is a perturbation. We assume that this perturbation is small, i.e. we assume that  $X_\mu$  nearly splits according to (3). In this case there exists a  $C^r$  manifold (torus)  $T^k$  close to  $\tilde{T}^k$  which is invariant for  $X_\mu$  and attracting<sup>\*)</sup>. The condition that

---

<sup>\*)</sup> This follows from Kelley [7] Theorem 4 and Theorem 5, and also from recent work of Pugh (unpublished). That  $T^k$  is attracting means that it has a neighbourhood  $U$  such that  $\bigcap_{t>0} \mathcal{G}_{X,t}(U) = T^k$ . We cannot call  $T^k$  an attractor because it need not consist of non-wandering points

$X_\mu - X_\mu^s$  be small depends on how attracting the closed orbits  $\Gamma_1, \dots, \Gamma_k$  are for the vector field  $X_{\mu_1}^s, \dots, X_{\mu_k}^s$ ; therefore the condition is violated if  $\mu$  becomes too close to one of the  $\mu_i$ .

We consider now the vector field  $X_\mu$  restricted to  $T^k$ . For reasons already discussed, we do not expect that the motion will remain quasi-periodic. If  $k = 2$ , Peixoto's theorem implies that generically the non-wandering set of  $T^2$  consists of a finite number of fixed points and closed orbits. What will happen in the case which we consider is that there will be one (or a few) attracting closed orbits with frequencies  $\omega_1, \omega_2$  such that  $\omega_1 / \omega_2$  goes continuously through rational values.

Let  $k > 2$ . In that case, the vector fields on  $T^k$  for which the non-wandering set consists of a finite number of fixed points and closed orbits are no longer dense in the appropriate Banach space. Other possibilities are realized which correspond to a more complicated orbit structure; "strange" attractors appear like the one presented at the end of Section 2. Taking the case of  $T^4$  and the  $C^3$ -topology we shall show in Section 9 that in any neighbourhood of a quasi-periodic  $X^s$  there is an open set of vector fields with a strange attractor.

We propose to say that the motion of a fluid system is turbulent when this motion is described by an integral curve of the vector field  $X_\mu$  which tends to a set  $A^*$ , and  $A$  is neither empty nor a

---

\*) More precisely  $A$  is the  $\omega^+$  limit set of the integral curve  $x(\cdot)$ , i.e., the set of points  $\xi$  such that there exists a sequence  $(t_n)$  and  $t_n \rightarrow \infty$ ,  $x(t_n) \rightarrow \xi$ .

fixed point nor a closed orbit. In this definition we disregard nongeneric possibilities (like  $A$  having the shape of the figure 8, etc.).

This proposal is based on two things

(a) We have shown that, when  $\mu$  increases, it is not unlikely that an attractor  $A$  will appear which is neither a point nor a closed orbit.

(b) In the known generic examples where  $A$  is not a point or a closed orbit, the structure of the integral curves on or near  $A$  is complicated and erratic (see Smale [11] and Williams [13]).

We shall further discuss the above definition of turbulent motion in Section 4.



§ 3. b. Bifurcations of a closed orbit.

We have seen above how an attracting fixed point of  $X_\mu$  may be replaced by an attracting closed orbit  $\gamma_\mu$  when the parameter crosses the value  $\mu_1$  (Hopf bifurcation). We consider now in some detail the next bifurcation; we assume that it occurs at the value  $\mu'$  of the parameter <sup>\*)</sup> and that  $\lim_{\mu \rightarrow \mu'} \gamma_\mu$  is a closed orbit  $\gamma_{\mu'}$  of  $X_{\mu'}$  <sup>\*\*)</sup>.

Let  $\Phi_\mu$  be the Poincaré map associated with a piece of hypersurface  $S$  transversal to  $\gamma_\mu$ , for  $\mu \in (\mu_1, \mu']$ . Since  $\gamma_\mu$  is attracting,  $p_\mu = S \cap \gamma_\mu$  is an attracting fixed point of  $\Phi_\mu$  for  $\mu \in (\mu_1, \mu')$ . The derivative  $d\Phi_\mu(p_\mu)$  of  $\Phi_\mu$  at the point  $p_\mu$  is a linear map of the tangent hyperplane to  $S$  at  $p_\mu$  to itself.

We assume that the spectrum of  $d\Phi_{\mu'}(p_{\mu'})$  consists of a finite number of isolated eigenvalues of absolute value 1, and a part which is contained in the open unit disc  $\{z \in \mathbb{C} \mid |z| < 1\}$  <sup>\*\*\*)</sup>. According to § 5, remark (5.6), we may assume that  $S$  is finite dimensional.

---

<sup>\*)</sup> In general  $\mu'$  will differ from the value  $\mu_2$  introduced in § 3.a.

<sup>\*\*\*)</sup> There are also other possibilities: If  $\gamma_\mu$  tends to a point we have a Hopf bifurcation with parameter reversed. The cases where  $\lim_{\mu \rightarrow \mu'} \gamma_\mu$  is not compact or where the period of  $\gamma_\mu$  tends to  $\infty$  are not well understood; they may or may not give rise to turbulence.

<sup>\*\*\*\*)</sup> If the spectrum of  $d\Phi_{\mu'}(p_{\mu'})$  is discrete, this is a reasonable assumption, because for  $\mu_1 < \mu < \mu'$  the spectrum is contained in the open unit disc.

With this assumption one can say rather precisely what kind of generic bifurcations are possible for  $\mu = \mu'$ . We shall describe these bifurcations by indicating what kind of attracting subsets for  $X_\mu$  (or  $\Phi_\mu$ ) there are near  $\gamma_{\mu'}$  (or  $p_{\mu'}$ ) when  $\mu > \mu'$ .

Generically, the set  $E$  of eigenvalues of  $d\Phi_{\mu'}(p_{\mu'})$ , with absolute value 1, is of one of the following types:

1.  $E = \{ + 1 \}$
2.  $E = \{ - 1 \}$
3.  $E = \{ \alpha, \bar{\alpha} \}$  where  $\alpha, \bar{\alpha}$  are distinct.

For the cases 1 and 2 we can refer to P. Brunovsky [3]. In fact in case 1 the attracting closed orbit disappears (together with a hyperbolic closed orbit); for  $\mu > \mu'$  there is no attractor of  $X_\mu$  near  $\gamma_{\mu'}$ . In case 2 there is for  $\mu > \mu'$  (or  $\mu < \mu'$ ) an attracting (resp. hyperbolic) closed orbit near  $\gamma_{\mu'}$ , but the period is doubled.

If we have case 3 then  $\Phi_\mu$  has also for  $\mu$  slightly bigger than  $\mu'$  a fixed point  $p_\mu$ ; generically the conditions (a)', ..., (e) in theorem (7.2) are satisfied. One then concludes that when  $\gamma_{\mu'}$  is a "vague attractor" (i.e. when the condition (f) is satisfied) then, for  $\mu > \mu'$ , there is an attracting circle for  $\Phi_\mu$ ; this amounts to the existence of an invariant and attracting torus  $T^2$  for  $X_\mu$ . If  $\gamma_{\mu'}$  is not a "vague attractor" then, generically,  $X_\mu$  has no attracting set near  $\gamma_{\mu'}$  for  $\mu > \mu'$ .

§ 4. Some remarks on the definition of turbulence.

We conclude this discussion by a number of remarks

(1) The concept of genericity based on residual sets may not be the appropriate one from the physical view point. In fact the complement of a residual set of the  $\mu$ -axis need not have Lebesgue measure zero. In particular the quasi-periodic motions which we had eliminated may in fact occupy a part of the  $\mu$ -axis with non vanishing Lebesgue measure<sup>\*)</sup>. These quasi-periodic motions would be considered turbulent by our definition, but the "turbulence" would be weak for small  $k$ . There are arguments to define the quasi-periodic motions, along with the periodic ones, as non turbulent (see (4) below).

(2) By our definition, a periodic motion (= closed orbit of  $X_\mu$ ) is not turbulent. It may however be very complicated and appear turbulent (think of a periodic motion closely approximating a quasi-periodic one, see § 3. b, second footnote).

(3) We have shown that, under suitable conditions, there is an attracting torus  $T^k$  for  $X_\mu$  if  $\mu$  is between  $\mu_k$  and  $\mu_{k+1}$ . We assumed in the proof that  $\mu$  was not too close to  $\mu_k$  or  $\mu_{k+1}$ . In fact the transition from  $T^1$  to  $T^2$  is described in Section 3.b, but the

---

<sup>\*)</sup> On the torus  $T^2$ , the rotation number  $\omega$  is a continuous function of  $\mu$ . Suppose one could prove that, on some  $\mu$ -interval,  $\omega$  is non constant and is absolutely continuous with respect to Lebesgue measure; then  $\omega$  would take irrational values on a set of non zero Lebesgue measure.

transition from  $T^k$  to  $T^{k+1}$  appears to be a complicated affair when  $k > 1$ . In general, one gets the impression that the situations not covered by our description are more complicated, hard to describe, and probably turbulent.

(4) An interesting situation arises when statistical properties of the motion can be obtained, via the pointwise ergodic theorem, from an ergodic measure  $m$  supported by the attracting set  $A$ . An observable quantity for the physical system at a time  $t$  is given by a function  $x_t$  on  $H$ , and its expectation value is  $m(x_t) = m(x_0)$ . If  $m$  is "mixing" the time correlation functions  $m(x_t y_0) - m(x_0) m(y_0)$  tend to zero as  $t \rightarrow \infty$ . This situation appears to prevail in turbulence, and "pseudo random" variables with correlation functions tending to zero at infinity have been studied by Bass<sup>\*)</sup>. With respect to this property of time correlation functions the quasi-periodic motions should be classified as non turbulent.

(5) In the above analysis the detailed structure of the equations describing a viscous fluid has been totally disregarded. Of course something is known of this structure, and also of the experimental conditions under which turbulence develops, and a theory should be obtained in which these things are taken into account.

---

<sup>\*)</sup> See for instance [2].

Chapter II.

§ 5. Reduction to two dimensions.

Definition (5.1). Let  $\Phi : H \rightarrow H$  be a  $C^1$  map with fixed point  $p \in H$ , where  $H$  is a Hilbert space. The spectrum of  $\Phi$  at  $p$  is the spectrum of the induced map  $(d\Phi)_p : T_p(H) \rightarrow T_p(H)$ .

Let  $X$  be a  $C^1$  vectorfield on  $H$  which is zero in  $p \in H$ . For each  $t$  we then have  $d(\Phi_{X,t})_p : T_p(H) \rightarrow T_p(H)$ , induced by the time  $t$  integral of  $X$ . Let  $L(X) : T_p(H) \rightarrow T_p(H)$  be the unique continuous linear map such that  $d(\Phi_{X,t})_p = e^{t.L(X)}$ . We define the spectrum of  $X$  at  $p$  to be the spectrum of  $L(X)$  (Note that  $L(X)$  also can be obtained by linearizing  $X$ ).

Proposition (5.2). Let  $X_\mu$  be a one-parameter family of  $C^k$  vectorfields on a Hilbertspace  $H$  such that also  $X$ , defined by  $X(h, \mu) = (X_\mu(h), 0)$ , on  $H \times \mathbb{R}$  is  $C^k$ . Suppose:

- (a)  $X_\mu$  is zero in the origin of  $H$ .
- (b) For  $\mu < 0$  the spectrum of  $X_\mu$  in the origin is contained in  $\{z \in \mathbb{C} \mid \text{Re}(z) < 0\}$ .
- (c) For  $\mu = 0$ , resp.  $\mu > 0$ , the spectrum of  $X_\mu$  at the origin has two isolated eigenvalues  $\lambda(\mu)$  and  $\overline{\lambda(\mu)}$  with multiplicity one and  $\text{Re}(\lambda(\mu)) = 0$ , resp.  $\text{Re}(\lambda(\mu)) > 0$ . The remaining part of the spectrum is contained in  $\{z \in \mathbb{C} \mid \text{Re}(z) < 0\}$ .

Then there is a (small) 3-dimensional  $C^k$ -manifold  $\tilde{V}^c$  of  $H \times \mathbb{R}$  containing  $(0, 0)$  such that:

1.  $\overset{\infty}{V}^c$  is locally invariant under the action of the vectorfield X  
 ( X is defined by  $X(h, \mu) = (X_\mu(h), 0)$  ); locally invariant means  
that there is a neighbourhood U of (0, 0) such that for  
 $|t| \leq 1$  ,  $\overset{\infty}{V}^c \cap U = \mathcal{D}_{X,t}(\overset{\infty}{V}^c) \cap U$  .
2. There is a neighbourhood U' of (0, 0) such that if  $p \in U'$  ,  
is recurrent, and has the property that  $\mathcal{D}_{X,t}(p) \in U'$  for all t ,  
then  $p \in \overset{\infty}{V}^c$
3. in (0, 0)  $\overset{\infty}{V}^c$  is tangent to the  $\mu$  axis and to the eigenspace of  
 $\lambda(0)$  ,  $\overline{\lambda(0)}$  .

Proof: We construct the following splitting  $T_{(0,0)}(H \times \mathbb{R}) = V^c \oplus V^s$  :  
 $V^c$  is tangent to the  $\mu$  axis and contains the eigenspace of  $\lambda(\mu)$  ,  
 $\overline{\lambda(\mu)}$  ;  $V^s$  is the eigenspace corresponding to the remaining (compact)  
 part of the spectrum of  $L(X)$  . Because this remaining part is compact  
 there is a  $\delta > 0$  such that it is contained in  $\{z \in \mathbb{C} \mid \text{Re}(z) < -\delta\}$  .  
 We can now apply the centermanifold theorem [5], the proof of which  
 generalizes to the case of a Hilbert space, to obtain  $\overset{\infty}{V}^c$  as the center-  
 manifold of X at (0, 0) [by assumption X is  $C^k$  , so  $\overset{\infty}{V}^c$  is  $C^k$  :  
 if we would assume only that, for each  $\mu$ ,  $X_\mu$  is  $C^k$  (and X only  
 $C^1$  ), then  $\overset{\infty}{V}^c$  would be  $C^1$  but, for each  $\mu_0$ ,  $\overset{\infty}{V}^c \cap \{\mu = \mu_0\}$  would be  
 $C^k$  ].

For positive t,  $d(\mathcal{D}_{X,t})_{(0,0)}$  induces a contraction on  $V^s$   
 (the spectrum is contained in  $\{z \in \mathbb{C} \mid |z| < e^{-\delta t}\}$  ). Hence there is a

neighbourhood  $U'$  of  $(0, 0)$  such that

$U' \cap \left[ \bigcap_{t=1}^{\infty} \mathcal{D}_{X,t}(U') \right] \subset (U' \cap \overset{u}{V}^c)$  . Now suppose that  $p \in U'$  is recurrent and that  $\mathcal{D}_{X,t}(p) \in U'$  for all  $t$  . Then given  $\epsilon > 0$  and  $N > 0$  there is a  $t > N$  such that the distance between  $p$  and  $\mathcal{D}_{X,t}(p)$  is  $< \epsilon$  . It then follows that  $p \in \overline{(U' \cap \overset{u}{V}^c)} \subset \overset{u}{V}^c$  for  $U'$  small enough. This proves the proposition.

Remark (5.3). The analogous proposition for a one parameter set of diffeomorphisms  $\Phi_{\mu}$  is proved in the same way. The assumptions are then:

- (a)' The origin is a fixed point of  $\Phi_{\mu}$  .
- (b)' For  $\mu < 0$  the spectrum of  $\Phi_{\mu}$  at the origin is contained in  $\{z \in \mathbb{C} \mid |z| < 1\}$  .
- (c)' For  $\mu = 0$  resp.  $\mu > 0$  the spectrum of  $\Phi_{\mu}$  at the origin has two isolated eigenvalues  $\lambda(\mu)$  and  $\overline{\lambda(\mu)}$  with multiplicity one and  $|\lambda(\mu)| = 1$  resp.  $|\lambda(\mu)| > 1$  . The remaining part of the spectrum is contained in  $\{z \in \mathbb{C} \mid |z| < 1\}$  .

One obtains just as in proposition ( 5.2) a 3-dimensional center manifold which contains all the local recurrence.

Remark (5.4). If we restrict the vectorfield  $X$  , or the diffeomorphism  $\Phi$  (defined by  $\Phi(h, \mu) = (\Phi_{\mu}(h), \mu)$  ), to the 3-dimensional manifold  $\overset{u}{V}^c$  we have locally the same as in the assumptions (a), (b), (c), or

- (a)', (b)', (c)' where now the Hilbert space has dimension 2. So if we want to prove a property of the local recurrent points for a one parameter family of vectorfield, or diffeomorphisms, satisfying (a) (b) and (c), or (a)', (b)' and (c)', it is enough to prove it for the case where  $\dim(H) = 2$  .

Remark (5.5). Everything in this section holds also if we replace our Hilbert space by a Banach space with  $C^k$ -norm; a Banach space  $B$  has  $C^k$ -norm if the map  $x \rightarrow \|x\|$ ,  $x \in B$  is  $C^k$  except at the origin. This  $C^k$ -norm is needed in the proof of the center manifold theorem.

Remark (5.6). The propositions (5.2) and (5.3) remain true if

1. we drop the assumptions on the spectrum of  $X_\mu$  resp.  $\Phi_\mu$  for  $\mu > 0$ .
2. we allow the spectrum of  $X_\rho$  resp.  $\Phi_\rho$  to have an arbitrary but finite number of isolated eigenvalues on the real axis resp. the unit circle.

The dimension of the invariant manifold  $\hat{V}^c$  is then equal to that number of eigenvalues plus one.



§ 6. The Hopf bifurcation.

We consider a one parameter family  $X_\mu$  of  $C^k$ -vectorfield on  $\mathbb{R}^2$ ,  $k \geq 5$ , as in the assumption of proposition (5.2) (with  $\mathbb{R}^2$  instead of  $H$ );  $\lambda(\mu)$  and  $\overline{\lambda(\mu)}$  are the eigenvalues of  $X_\mu$  in  $(0, 0)$ .

Notice that with a suitable change of coordinates we can achieve

$X_\mu = (\operatorname{Re} \lambda(\mu)x_1 + \operatorname{Im} \lambda(\mu)x_2) \frac{\partial}{\partial x_1} + (-\operatorname{Im} \lambda(\mu)x_1 + \operatorname{Re} \lambda(\mu)x_2) \frac{\partial}{\partial x_2} + \text{terms of higher order.}$

Theorem (6.1) (Hopf [6]). If  $(\frac{d(\lambda(\mu))}{d\mu})_{\mu=0}$  has a positive real part, and if  $\lambda(0) \neq 0$ , then there is a one-parameter family of closed orbits of  $X(=X_\mu, 0)$  on  $\mathbb{R}^3 = \mathbb{R}^2 \times \mathbb{R}^1$  near  $(0, 0, 0)$  with period near  $\frac{2\pi}{|\lambda(0)|}$ ; there is a neighbourhood  $U$  of  $(0, 0, 0)$  in  $\mathbb{R}^3$  such that each closed orbit of  $X$ , which is contained in  $U$ , is a member of the above family.

If  $(0, 0)$  is a "vague attractor" (to be defined later) for  $X_0$ , then this one-parameter family is contained in  $\{\mu > 0\}$  and the orbits are of attracting type.

Proof. We first have to state and prove a lemma on polar-coordinates:

Lemma (6.2). Let  $X$  be a  $C^k$  vectorfield on  $\mathbb{R}^2$  and let  $X(0,0) = 0$ . Define polar coordinates by the map  $\Psi : \mathbb{R}^2 \rightarrow \mathbb{R}^2$ , with  $\Psi(r, \varphi) = (r \cos \varphi, r \sin \varphi)$ . Then there is a unique  $C^{k-2}$ -vectorfield  $\overset{\curvearrowright}{X}$  on  $\mathbb{R}^2$ , such that  $\Psi_* \overset{\curvearrowright}{X} = X$  (i.e. for each  $(r, \varphi)$   $d\Psi \overset{\curvearrowright}{X}(r, \varphi) = X(r \cos \varphi, r \sin \varphi)$ ).

Proof of Lemma (6.2). We can write  $X = X_1 \frac{\partial}{\partial x_1} + X_2 \frac{\partial}{\partial x_2} =$

$$= \frac{x_1 X_1 + x_2 X_2}{\sqrt{x_1^2 + x_2^2}} \left( \frac{1}{\sqrt{x_1^2 + x_2^2}} (x_1 \frac{\partial}{\partial x_1} + x_2 \frac{\partial}{\partial x_2}) \right) + \frac{(-x_2 X_1 + x_1 X_2)}{(x_1^2 + x_2^2)} (-x_2 \frac{\partial}{\partial x_1} + x_1 \frac{\partial}{\partial x_2}) =$$

$$= \frac{f_r(x_1, x_2)}{r} \cdot \tilde{Z}_r + \frac{f_\varphi(x_1, x_2)}{r^2} \tilde{Z}_\varphi .$$

Where  $\tilde{Z}_r (= \frac{\partial}{\partial r})$  and  $\tilde{Z}_\varphi (= \frac{\partial}{\partial \varphi})$  are the "coordinate vectorfields" with respect to  $(r, \varphi)$  and  $r = \pm \sqrt{x_1^2 + x_2^2}$  (Note that  $r$  and  $\tilde{Z}_r$  are bivalued.)

Now we consider the functions  $\tilde{\Psi}^*(f_r) = f_r \circ \tilde{\Psi}$  and  $\tilde{\Psi}^*(f_\varphi)$ . They are zero along  $\{r = 0\}$ ; this also holds for  $\frac{\partial}{\partial r}(\tilde{\Psi}^*(f_r))$  and  $\frac{\partial}{\partial r}(\tilde{\Psi}^*(f_\varphi))$ .

By the division theorem  $\frac{\tilde{\Psi}^*(f_r)}{r}$ , resp  $\frac{\tilde{\Psi}^*(f_\varphi)}{r^2}$ , are  $C^{k-1}$  resp.  $C^{k-2}$ .

We can now take  $\tilde{X} = \frac{\tilde{\Psi}^*(f_r)}{r} \tilde{Z}_r + \frac{\tilde{\Psi}^*(f_\varphi)}{r^2} \tilde{Z}_\varphi$ ; the uniqueness is evident.

Definition (6.3). We define a Poincaré map  $P_X$  for a vector-field  $X$  as in the assumptions of theorem (6.1):

$P_X$  is a map from  $\{(x_1, x_2, \mu) \mid |x_1| < \epsilon, x_2 = 0, |\mu| \leq \mu_0\}$  to the  $(x_1, \mu)$  plane;  $\mu_0$  is such that  $\text{Im}(\lambda(\mu)) \neq 0$  for  $|\mu| \leq \mu_0$ ;  $\epsilon$  is sufficiently small.  $P_X$  maps  $(x_1, x_2, \mu)$  to the first intersection point of  $\mathcal{D}_{X,t}(x_1, x_2, \mu)$ ,  $t > 0$ , with the  $(x_1, \mu)$  plane, for which the sign of  $x_1$  and the  $x_1$  coordinate of  $\mathcal{D}_{X,t}(x_1, x_2, \mu)$  are the same.

Remark (6.4).  $P_X$  preserves the  $\mu$  coordinate. In a plane  $\mu = \text{constant}$  the map  $P_X$  is illustrated in the following figure

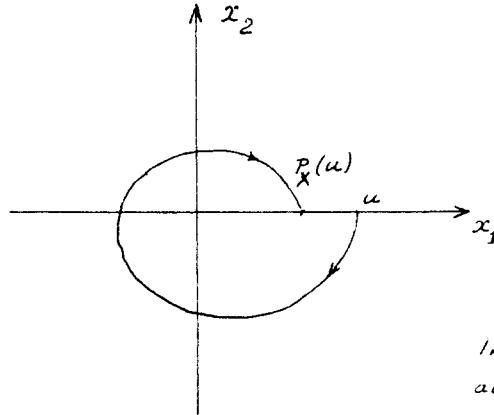

*Fig. 6.  
Integral curve of  $X$   
at  $\mu = \text{constant}$*

$\text{Im}(\lambda(u)) \neq 0$  means that  $X$  has a "non vanishing rotation" ; it is then clear that  $P_X$  is defined for  $\varepsilon$  small enough.

Remark (6.5). It follows easily from lemma (6.2) that  $P_X$  is  $C^{k-2}$ .

We define a displacement function  $V(x_1, \mu)$  on the domain of  $P_X$  as follows:

$$P_X(x_1, 0, \mu) = (x_1 + V(x_1, \mu), 0, \mu) ; V \text{ is } C^{k-2} .$$

This displacement function has the following properties:

- (i)  $V$  is zero on  $\{x_1 = 0\}$  ; the other zeroes of  $V$  occur in pairs (of opposite sign), each pair corresponds to a closed orbit of  $X$  . If a closed orbit  $\gamma$  of  $X$  is contained in a sufficiently small neighbourhood of  $(0, 0)$  , and intersects  $\{x_1=0\}$  only twice then  $V$  has a corresponding pair of zeroes (namely the two points  $\gamma \cap (\text{domain of } P_X)$  ) .

(ii) For  $\mu < 0$  and  $x_1 = 0$ ,  $\frac{\partial V}{\partial x_1} < 0$ ; for  $\mu > 0$  and  $x_1 = 0$ ,  $\frac{\partial V}{\partial x_1} > 0$  and for  $\mu = 0$  and  $x = 0$ ,  $\frac{\partial^2 V}{\partial \mu \partial x_1} > 0$ . This follows from the assumptions on  $\lambda(\mu)$ . Hence, again by the division theorem,  $\tilde{V} = \frac{V}{x_1}$  is  $C^{k-3}$ .  $\tilde{V}(0, 0)$  is zero,  $\frac{\partial \tilde{V}}{\partial \mu} > 0$ , so there is locally a unique  $C^{k-3}$ -curve  $\mathcal{L}$  of zeroes of  $\tilde{V}$  passing through  $(0, 0)$ . Locally the set of zeroes of  $V$  is the union of  $\mathcal{L}$  and  $\{x_1=0\}$ .  $\mathcal{L}$  induces the one-parameter family of closed orbits.

(iii) Let us say that  $(0, 0)$  is a "vague attractor" for  $X_0$  if  $V(x_1, 0) = -A x_1^3 + \text{terms of order } > 3$  with  $A > 0$ . This means that the 3<sup>rd</sup> order terms of  $X_0$  make the flow attract to  $(0, 0)$ . In that case  $\tilde{V} = \alpha_1 \mu - A x_1^2 + \text{terms of higher order}$ , with  $\alpha_1$  and  $A > 0$ , so  $\tilde{V}(x_1, \mu)$  vanishes only if  $x_1 = 0$  or  $\mu > 0$ . This proves that the one-parameter family is contained in  $\{\mu > 0\}$ .

(iv) The following holds in a neighbourhood of  $(0, 0, 0)$  where

$$\frac{\partial V}{\partial x_1} > -1$$

If  $V(x_1, \mu) = 0$  and  $\left(\frac{\partial V}{\partial x_1}\right)_{(x_1, \mu)} < 0$ , then the closed orbit which cuts the domain of  $P_X$  in  $(x_1, \mu)$  is an attractor of  $X_\mu$ . This follows from the fact that  $(x_1, \mu)$  is a fixed point of  $P_X$  and the fact that the derivative of  $P_X$  in  $(x_1, \mu)$ , restricted to this  $\mu$  level, is smaller than 1 (in absolute value).

Combining (iii) and (iv) it follows easily that, if  $(0, 0)$  is a vague attractor, the closed orbits of our one parameter family are, near  $(0, 0)$ ,

of the attracting type.

Finally we have to show that, for some neighbourhood  $U$  of  $(0, 0)$ , every closed orbit of  $X$ , which is contained in  $U$ , is a member of our family of closed orbits. We can make  $U$  so small that every closed orbit  $\gamma$  of  $X$ , which is contained in  $U$ , intersects the domain of  $P_X$ .

Let  $p = (x_1(\gamma), 0, \mu(\gamma))$  be an intersection point of a closed orbit  $\gamma$  with the domain of  $P_X$ . We may also assume that  $U$  is so small that  $P_X[U \cap (\text{domain of } P_X)] \subset (\text{domain of } P_X)$ . Then  $P_X(p)$  is in the domain of  $P_X$  but also  $P_X(p) \in U$  so  $(P_X)^2(p)$  is defined etc.; so  $P_X^i(p)$  is defined.

Restricted to  $\{\mu = \mu(\gamma)\}$ ,  $P_X$  is a local diffeomorphism of a segment of the half line  $(x_1 \geq 0 \text{ or } x_1 \leq 0, x_2 = 0, \mu = \mu(\gamma))$  into that half line.

If the  $x_1$  coordinate of  $P_X^i(p)$  is  $<$  (resp.  $>$ ) than  $x_1(\gamma)$  then the  $x_1$  coordinate of  $P_X^{i+1}(p)$  is  $<$  (resp.  $>$ ) than the  $x_1$  coordinate of  $P_X^i(p)$ , so  $p$  does not lie on a closed orbit. Hence we must assume that the  $x_1$  coordinate of  $P_X(p)$  is  $x_1(\gamma)$ , hence  $p$  is a fixed point of  $P_X$ , hence  $p$  is a zero of  $V$ , so, by property (ii),  $\gamma$  is a member of our one parameter family of closed orbits.

§ 7. Hopf bifurcation for diffeomorphisms.

We consider now a one parameter family  $\Phi_\mu : \mathbb{R}^2 \rightarrow \mathbb{R}^2$  of diffeomorphisms satisfying (a)', (b)' and (c)' (Remark (5.3)) and such that:

$$(d) \quad \frac{d}{d\mu} (|\lambda(\mu)|)_{\mu=0} > 0 .$$

Such a diffeomorphism can for example occur as the time one integral of a vectorfield  $X_\mu$  as we studied in section 2. In this diffeomorphism case we shall of course not find any closed (circular) orbit (the orbits are not continuous) but nevertheless we shall, under rather general conditions, find, near  $(0, 0)$  and for  $\mu$  small, a one parameter family of invariant circles

We first bring  $\Phi_\mu$ , by coordinate transformations, into a simple form:

We change the  $\mu$  coordinate in order to obtain

$$(d)' \quad |\lambda(\mu)| = 1 + \mu .$$

After an appropriate ( $\mu$  dependent) coordinate change of  $\mathbb{R}^2$  we then have  $\tilde{\Phi}(r, \varphi, \mu) = ((1 + \mu)r, \varphi + f(\mu), \mu) + \text{terms of order } r^2$ , where  $x_1 = r \cos \varphi$  and  $x_2 = r \sin \varphi$ ; " $\tilde{\Phi} = \tilde{\Phi}' + \text{terms of order } r^\ell$ " means that the derivatives of  $\tilde{\Phi}$  and  $\tilde{\Phi}'$  up to order  $\ell - 1$  with respect to  $(x_1, x_2)$  agree for  $(x_1, x_2) = (0, 0)$ .

We now put in one extra condition:

$$(e) \quad f(0) \neq \frac{k}{\ell} \cdot 2\pi \quad \text{for all } k, \ell \leq 5 .$$

Proposition (7.1). Suppose  $\Phi_\mu$  satisfies (a)', (b)', (c)', (d)' and (e) and is  $C^k$ ,  $k \geq 5$ . Then for  $\mu$  near 0, by a  $\mu$  dependent coordinate change in  $\mathbb{R}^2$ , one can bring  $\Phi_\mu$  in the following form:

$$\Phi_\mu(r, \varphi) = ((1 + \mu)r - f_1(\mu).r^3, \varphi + f_2(\mu) + f_3(\mu).r^2) + \text{terms of order } r^5.$$

For each  $\mu$ , the coordinate transformation of  $\mathbb{R}^2$  is  $C^\infty$ ; the induced coordinate transformation on  $\mathbb{R}^2 \times \mathbb{R}$  is only  $C^{k-4}$ .

The next paragraph is devoted to the proof of this proposition.

Our last condition on  $\Phi_\mu$  is:

(f)  $f_1(0) \neq 0$ . We assume even that  $f_1(0) > 0$  (this corresponds to the case of a vague attractor for  $\mu = 0$ , see section 6); the case  $f_1(0) < 0$  can be treated in the same way (by considering  $\Phi_{-\mu}^{-1}$  instead of  $\Phi_\mu$ ).

Notation: We shall use  $N\Phi_\mu$  to denote the map

$$(r, \varphi) \longrightarrow ((1+\mu)r - f_1(\mu).r^3, \varphi + f_2(\mu) + f_3(\mu).r^2)$$

and call this "the simplified  $\Phi_\mu$ ".

Theorem (7.2). Suppose  $\Phi_\mu$  is at least  $C^5$  and satisfies (a)', (b)', (c)', (d)' and (e) and  $N\Phi_\mu$ , the simplified  $\Phi_\mu$ , satisfies (f). Then there is a continuous one parameter family of invariant attracting circles of  $\Phi_\mu$ , one for each  $\mu \in (0, \epsilon)$ , for  $\epsilon$  small enough.

Proof: The idea of the proof is as follows:

the set  $\Sigma = \{\mu = f_1(\mu) \cdot r^2\}$  in  $(r, \varphi, \mu)$  - space is invariant under  $N\Phi$ ;  $N\Phi$  even "attracts to this set". This attraction makes  $\Sigma$  stable in the following sense:  $\{\Phi^n(\Sigma)\}_{n=0}^{\infty}$  is a sequence of manifolds which converges (for  $\mu$  small) to an invariant manifold (this is actually what we have to prove); the method of the proof is similar to the methods used in [4], [5].

First we define  $U_\delta = \{(r, \varphi, \mu) \mid r \neq 0 \text{ and } \frac{\mu}{r^2} \in [f_1(\mu) - \delta, f_1(\mu) + \delta]\}$ ,  $\delta \ll f_1(\mu)$ , and show that  $N\Phi(U_\delta) \subset U_\delta$  and also, in a neighbourhood of  $(0, 0, 0)$ ,  $\Phi(U_\delta) \subset U_\delta$ . This goes as follows:

If  $p \in \partial U_\delta$ , and  $r(p)$  is the  $r$ -coordinate of  $p$ , then the  $r$ -coordinate of  $N\Phi(p)$  is  $r(p) \pm \delta \cdot (r(p))^3$  and  $p$  goes towards the interior of  $U_\delta$ . Because  $\Phi$  equals  $N\Phi$ , modulo terms of order  $r^5$ , also, locally,  $\Phi(U_\delta) \subset U_\delta$ . From this it follows that, for  $\epsilon$  small enough and all  $n \geq 0$   $\Phi^n(\Sigma_\epsilon) \subset U_\delta$ ;  $\Sigma_\epsilon = \Sigma \cap \{0 < \mu < \epsilon\}$ .

Next we define, for vectors tangent to a  $\mu$  level of  $U_\delta$ , the slope by the following formula: for  $X$  tangent to  $U_\delta \cap \{\mu = \mu_0\}$  and  $X = X_r \frac{\partial}{\partial r} + X_\varphi \frac{\partial}{\partial \varphi}$  the slope of  $X$  is  $\left| \frac{X_r}{\mu_0 \cdot X_\varphi} \right|$ ; for  $X_\varphi = 0$  the slope is not defined.

By direct calculations it follows that if  $X$  is a tangent vector of  $U_\delta \cap \{\mu = \mu_0\}$  with slope  $\leq 1$ , and  $\mu_0$  is small enough, then the slope of  $d(N\Phi)(X)$  is  $\leq (1 - K\mu_0)$  for some positive  $K$ . Using this,



the fact that  $\frac{\mu}{r^2} \sim \text{constant}$  on  $U_\delta$  and the fact that  $\Phi$  and  $N\Phi$  only differ by terms of order  $r^5$  one can verify that for  $\epsilon$  small enough and  $X$  a tangent vector of  $U_\delta \cap \{\mu = \mu_0\}$ ,  $\mu_0 \leq \epsilon$ , with slope  $\leq 1$ ,  $d\Phi(X)$  has slope  $< 1$ .

From this it follows that for  $\epsilon$  small enough and any  $n \geq 0$ ,

1.  $\Phi^n(\Sigma_\epsilon) \subset U_\delta$  and
2. the tangent vectors of  $\Phi^n(\Sigma_\epsilon) \cap \{\mu = \mu_0\}$ , for  $\mu_0 \leq \epsilon$  have slope  $< 1$ .

This means that for any  $\mu_0 \leq \epsilon$  and  $n \geq 0$

$\Phi^n(\Sigma_\epsilon) \cap \{\mu = \mu_0\} = \{(f_{n,\mu_0}(\varphi), \varphi, \mu_0)\}$ , where  $f_{n,\mu_0}$  is a unique

smooth function satisfying:

$$1'. \quad f_{n,\mu_0}(\varphi) \in \left[ \sqrt{\frac{\mu_0}{f_1(\mu_0) + \delta}}, \sqrt{\frac{\mu_0}{f_1(\mu_0) - \delta}} \right] \quad \text{for all } \varphi$$

$$2'. \quad \frac{d}{d\varphi} (f_{n,\mu_0}(\varphi)) \leq \mu_0 \quad \text{for all } \varphi.$$

We now have to show that, for  $\mu_0$  small enough,  $\{f_{n,\mu_0}\}_{n=0}^{\infty}$  converges.

We first fix a  $\varphi_0$  and define

$$p_1 = (f_n(\varphi_0), \varphi_0, \mu_0) \qquad p'_1 = \Phi(p_1) = (r'_1, \varphi'_1, \mu)$$

$$p_2 = (f_{n+1}(\varphi_0), \varphi_0, \mu_0) \qquad p'_2 = \Phi(p_2) = (r'_2, \varphi'_2, \mu).$$

Using again the fact that  $(f_{n,\mu_0}(\varphi))^2 / \mu_0 \sim \text{constant}$  (independent of  $\mu_0$ ),

one obtains:

$$|r'_1 - r'_2| \leq (1 - K_1 \mu_0) |f_{n, \mu_0}(\varphi_0) - f_{n+1, \mu_0}(\varphi_0)| \quad \text{and}$$

$$|\varphi'_1 - \varphi'_2| \leq K_2 \sqrt{\mu_0} |f_{n, \mu_0}(\varphi_0) - f_{n+1, \mu_0}(\varphi_0)| \quad \text{where } K_1, K_2 > 0$$

and independent of  $\mu_0$ .

By definition we have  $f_{n+1, \mu_0}(\varphi'_1) = r'_1$  and  $f_{n+2, \mu_0}(\varphi'_2) = r'_2$ .

We want however to get an estimate for the difference between

$f_{n+1, \mu_0}(\varphi'_1)$  and  $f_{n+2, \mu_0}(\varphi'_1)$ . Because  $\frac{d}{d\varphi}(f_{n+2, \mu_0}(\varphi)) \leq \mu_0$ ,

$$|f_{n+2, \mu_0}(\varphi'_2) - f_{n+2, \mu_0}(\varphi'_1)| \leq \mu_0 |\varphi'_2 - \varphi'_1| \leq K_2 \mu_0^{3/2} |f_{n, \mu_0}(\varphi_0) - f_{n+1, \mu_0}(\varphi_0)|$$

We have seen that  $|f_{n+1, \mu_0}(\varphi'_1) - f_{n+2, \mu_0}(\varphi'_2)| = |r'_1 - r'_2|$

$$\leq (1 - K_1 \mu_0) |f_{n, \mu_0}(\varphi_0) - f_{n+1, \mu_0}(\varphi_0)|.$$

So  $|f_{n+1, \mu_0}(\varphi'_1) - f_{n+2, \mu_0}(\varphi'_1)| \leq (1 + K_2 \mu_0^{3/2} - K_1 \mu_0) |f_{n, \mu_0}(\varphi_0) - f_{n+1, \mu_0}(\varphi_0)|$

We shall now assume that  $\mu_0$  is so small that  $(1 + K_2 \mu_0^{3/2} - K_1 \mu_0) = K_3(\mu_0) < 1$ ,

and write  $\rho(f_{n, \mu_0}, f_{n+1, \mu_0}) = \max_{\varphi} (|f_{n, \mu_0}(\varphi) - f_{n+1, \mu_0}(\varphi)|)$ .

It follows that

$$\rho(f_{m, \mu_0}, f_{m+1, \mu_0}) \leq (K_3(\mu_0))^m \cdot \rho(f_{0, \mu_0}, f_{1, \mu_0})$$

This proves convergence, and gives for each small  $\mu_0 > 0$  an invariant

and attracting circle. This family of circles is continuous because the limit functions  $f_{\infty, \mu_0}$  depend continuously on  $\mu_0$ , because of uniform convergence.

Remark (7.3). For a given  $\mu_0$ ,  $f_{\infty, \mu_0}$  is not only continuous but even Lipschitz, because it is the limit of functions with derivative  $\leq \mu_0$ . Now we can apply the results on invariant manifolds in [4], [5] and obtain the following:

If  $\Phi_{\mu}$  is  $C^r$  for each  $\mu$  then there is an  $\epsilon_r > 0$  such that the circles of our family which are in  $\{0 < \mu < \epsilon_r\}$  are  $C^r$ . This comes from the fact that near  $\mu = 0$  in  $U_{\delta}$  the contraction in the  $r$ -direction dominates sufficiently the maximal possible contraction in the  $\varphi$ -direction.

§ 8. Normal forms (the proof of proposition (7.1)).

First we have to give some definitions. Let  $\underline{V}_r$  be the vector-space of  $r$ -jets of vectorfields on  $\mathbb{R}^2$  in  $0$ , whose  $(r-1)$ -jet is zero (i.e. the elements of  $\underline{V}_r$  can be uniquely represented by a vectorfield whose component functions are homogeneous polynomials of degree  $r$ ).

$V_r$  is the set of  $r$ -jets of diffeomorphisms  $(\mathbb{R}^2, 0) \rightarrow (\mathbb{R}^2, 0)$ , whose  $(r-1)$ -jet is "the identity".  $\text{Exp} : \underline{V}_r \rightarrow V_r$  is defined by: for  $\alpha \in \underline{V}_r$ ,  $\text{Exp}(\alpha)$  is the  $(r$ -jet of) the diffeomorphism obtained by integrating  $\alpha$  over time 1.

Remark (8.1). For  $r \geq 2$ ,  $\text{Exp}$  is a diffeomorphism onto and  $\text{Exp}(\alpha) \circ \text{Exp}(\beta) = \text{Exp}(\alpha + \beta)$ . The proof is straightforward and left to the reader.

Let now  $A : (\mathbb{R}^2, 0) \rightarrow (\mathbb{R}^2, 0)$  be a linear map. The induced transformations  $A_r : \underline{V}_r \rightarrow \underline{V}_r$  are defined by  $A_r(\alpha) = A_*\alpha$ , or, equivalently,  $\text{Exp}(A_r(\alpha)) = A \circ \text{Exp} \alpha \circ A^{-1}$ .

Remark (8.2). If  $[\Psi]_r$  is the  $r$ -jet of  $\Psi : (\mathbb{R}^2, 0) \rightarrow (\mathbb{R}^2, 0)$  and  $d\Psi$  is  $A$ , then, for every  $\alpha \in \underline{V}_r$ , the  $r$ -jets  $[\Psi]_r \circ \text{Exp}(\alpha)$  and  $\text{Exp}(A_r \alpha) \circ [\Psi]_r$  are equal. The proof is left to the reader.

A splitting  $\underline{V}_r = \underline{V}'_r \oplus \underline{V}''_r$  of  $\underline{V}_r$  is called an A-splitting,

$A : (\mathbb{R}^2, 0) \rightarrow (\mathbb{R}^2, 0)$  linear, if

1.  $\underline{V}'_r$  and  $\underline{V}''_r$  are invariant under the action of  $A_r$
2.  $A_r|_{\underline{V}''_r}$  has no eigenvalue one.

Example (8.3). We take  $A$  with eigenvalues  $\lambda, \bar{\lambda}$  and such that  $|\lambda| \neq 1$  or such that  $|\lambda| = 1$  but  $\lambda \neq e^{k/2} 2\pi i$  with  $k, \ell \leq 5$ . We may assume that  $A$  is of the form

$$|\lambda| \begin{pmatrix} \cos \alpha & \sin \alpha \\ -\sin \alpha & \cos \alpha \end{pmatrix}. \text{ For } 2 \leq i \leq 4 \text{ we can obtain a } A\text{-splitting of}$$

$\underline{V}_i$  as follows:

$\underline{V}'_i$  is the set of those (i-jets of) vectorfields which are, in polar coordinates of the form  $\alpha_1 r^i \frac{\partial}{\partial r} + \alpha_2 r^{i-1} \frac{\partial}{\partial \varphi}$ . More precisely  $\underline{V}'_2 = 0$ ,  $\underline{V}'_3$  is generated by  $r^3 \frac{\partial}{\partial r}$  and  $r^2 \frac{\partial}{\partial \varphi}$  and  $\underline{V}'_4 = 0$

(the other cases give rise to vectorfields which are not differentiable, in ordinary coordinates).

$\underline{V}''_i$  is the set of (i-jets of) vectorfields of the form

$$g_1(\varphi) r^i \frac{\partial}{\partial r} + g_2(\varphi) r^{i-1} \frac{\partial}{\partial \varphi} \text{ with } \int_0^{2\pi} g_1(\varphi) = \int_0^{2\pi} g_2(\varphi) = 0.$$

$g_1(\varphi)$  and  $g_2(\varphi)$  have to be linear combinations of  $\sin(j \cdot \varphi)$  and  $\cos(j \cdot \varphi)$ ,  $j \leq 5$ , because otherwise the vectorfield will not be differentiable in ordinary coordinates (not all these linear combinations are possible).

Proposition (8.4). For a given diffeomorphism  $\Phi: (\mathbb{R}^2, 0) \rightarrow (\mathbb{R}^2, 0)$  with  $(d\Phi)_0 = A$  and a given A-splitting  $\underline{V}_i = \underline{V}'_i \oplus \underline{V}''_i$  for  $2 \leq i \leq i_0$ , there is a coordinate transformation  $\kappa: (\mathbb{R}^2, 0) \rightarrow (\mathbb{R}^2, 0)$  such that:

1.  $(d\kappa)_0 = \text{identity}$
2. For each  $z \leq i \leq i_0$  the  $i$ -jet of  $\Phi' = \kappa \circ \Phi \circ \kappa^{-1}$  is related to its  $(i-1)$ -jet as follows: Let  $[\Phi']_{i-1}$  be the polynomial map of degree  $\leq i-1$  which has the same  $(i-1)$ -jet. The  $i$ -jet of  $\Phi'$  is related to its  $(i-1)$ -jet if there is an element  $\alpha \in \underline{V}_i'$  such that  $\text{Exp } \alpha \circ [\Phi']_{i-1}$  has the same  $i$ -jet as  $\Phi'$ .

Proof. We use induction: Suppose we have a map  $\kappa$  such that 1 and 2 hold for  $i < i_1 \leq i_0$ . Consider the  $i_1$  jet of  $\kappa \circ \Phi \circ \kappa^{-1}$ . We now replace  $\kappa$  by  $\text{Exp } \alpha \circ \kappa$  for some  $\alpha \in \underline{V}_{i_1}''$ .  $\kappa \circ \Phi \circ \kappa^{-1}$  is then replaced by  $\text{Exp}(\alpha) \circ \kappa \circ \Phi \circ \kappa^{-1} \circ \text{Exp}(-\alpha)$ , according to remark (8.2) this equal to  $\text{Exp}(-A_{i_1} \alpha) \circ \text{Exp}(\alpha) \circ \kappa \circ \Phi \circ \kappa^{-1} = \text{Exp}(\alpha - A_{i_1} \alpha) \circ \kappa \circ \Phi \circ \kappa^{-1}$ .

$A_{i_1} | \underline{V}_{i_1}''$  has no eigenvalue one, so for each  $\beta \in \underline{V}_{i_1}''$  there is a unique  $\alpha \in \underline{V}_{i_1}''$  such that if we replace  $\kappa$  by  $\text{Exp } \alpha \circ \kappa$ ,  $\kappa \circ \Phi \circ \kappa^{-1}$  is replaced by  $\text{Exp } \beta \circ \kappa \circ \Phi \circ \kappa^{-1}$ . It now follows easily that there is a unique  $\alpha \in \underline{V}_{i_1}''$  such that  $\text{Exp } \alpha \circ \kappa$  satisfies condition 2 for  $i \leq i_1$ .

This proves the proposition.

Proof of proposition (7.1). For  $\mu$  near 0,  $d\hat{\Phi}_\mu$  is a linear map of the type we considered in example (8.3). So the splitting given there is a  $d\hat{\Phi}_\mu$ -splitting of  $\underline{V}_i$ ,  $i = 2, 3, 4$ , for  $\mu$  near zero. We now apply proposition (8.4) for each  $\mu$  and obtain a coordinate transformation  $\kappa_\mu$  for each  $\mu$  which brings  $\hat{\Phi}_\mu$  in the required form. The induction step then becomes:

Given  $\kappa_\mu$ , satisfying 1 and 2 for  $i < i_1$  there is for each  $\mu$  a unique  $\alpha_\mu \in V_{-i_1}''$  such that  $\text{Exp } \alpha_\mu \circ \kappa_\mu$  satisfies 1 and 2 for  $i \leq i_1$ .  $\alpha_\mu$  depends then  $C^r$  on  $\mu$  if the  $i_1$ -jet of  $\Phi$  depends  $C^r$  on  $\mu$ ; this gives the loss of differentiability in the  $\mu$  direction.

§ 9. Some examples.

In this section we show how a small perturbation of a quasi-periodic flow on a torus gives flows with strange attractors (Proposition (9.2)) and, more generally, flows which are not Morse-Smale (Proposition (9.1)).

Proposition (9.1). Let  $\omega$  be a constant vector field on  $T^k = (\mathbb{R}/\mathbb{Z})^k$ ,  $k \geq 3$ . In every  $C^{k-1}$ -small neighbourhood of  $\omega$  there exists an open set of vector fields which are not Morse-Smale.

We consider the case  $k = 3$ . We let  $\omega = (\omega_1, \omega_2, \omega_3)$  and we may suppose  $0 \leq \omega_1 \leq \omega_2 \leq \omega_3$ . Given  $\epsilon > 0$  we may choose a constant vector field  $\omega'$  such that

$$\|\omega' - \omega\|_2 = \|\omega' - \omega\|_0 < \epsilon/2$$

$$\omega'_3 > 0, \quad 0 < \frac{\omega'_1}{\omega'_3} = \frac{p_1}{q_1} < 1, \quad 0 < \frac{\omega'_2}{\omega'_3} = \frac{p_2}{q_2} < 1$$

where  $p_1, p_2, q_1, q_2$  are integers, and  $p_1 q_2$  and  $p_2 q_1$  have no common divisor. We shall also need that  $q_1, q_2$  are sufficiently large and satisfy

$$\frac{1}{2} < q_1/q_2 < 2$$

All these properties can be satisfied with  $q_1 = 2^{m_1}$ ,  $q_2 = 3^{m_2}$ .

Let  $I = \{x \in \mathbb{R} : 0 \leq x \leq 1\}$  and define  $g, h : I^3 \rightarrow T^3$  by



$$g(x_1, x_2, x_3) = (x_1 \pmod{1}, x_2 \pmod{1}, x_3 \pmod{1})$$

$$h(x_1, x_2, x_3) = (q_1^{-1}x_1 + p_1q_2x_3 \pmod{1}, q_2^{-1}x_2 + p_2q_1x_3 \pmod{1}, q_1q_2x_3 \pmod{1})$$

We have  $g I^3 = h I^3 = T^3$  and  $g$  (resp.  $h$ ) has a unique inverse on points  $gx$  (resp.  $hx$ ) with  $x \in I^3$ .

We consider the map  $f$  of a disc into itself (see [11] Sec. I.5, Fig. 7) used by Smale to define the horseshoe diffeomorphism.

Imbedding  $\Delta$  in  $T^2$  :

$$\Delta \subset \{(x_1, x_2) : \frac{1}{3} < x_1 < \frac{2}{3}, \frac{1}{3} < x_2 < \frac{2}{3}\} \subset T^2$$

we can arrange that  $f$  appears as Poincaré map in  $T^3 = T^2 \times T^1$ .

More precisely, it is easy to define a vector field  $X = (\tilde{X}, 1)$  on  $T^2 \times T^1$  such that if  $\xi \in \Delta$ , we have

$$(f(\xi), 0) = \Phi_{X,1}(\xi, 0)$$

where  $\Phi_{X,1}$  is the time one integral of  $X$  (see Fig. 7).

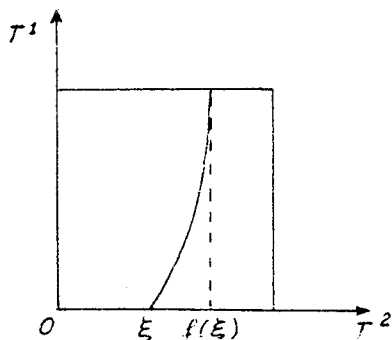

Fig. 7.

Finally we choose the restriction of  $X$  to a neighbourhood of  $g(\partial I^2 \times I)$  to be  $(0, 1)$  (i.e.  $\tilde{X} = 0$ ).

If  $x \in g \dot{I}^3$ , then  $\Phi x = h \circ g^{-1}$  is uniquely defined and the tangent mapping to  $\Phi$  applied to  $X$  gives a vector field  $Y$ :

$$Y(\Phi(x)) = [d \Phi(x)] X(x)$$

where

$$[d \Phi(x)] = \begin{pmatrix} q_1^{-1} & & p_1 & q_2 \\ & q_2^{-1} & p_2 & q_1 \\ & & q_1 & q_2 \end{pmatrix}$$

$Y$  has a unique smooth extension to  $T^3$ , again called  $Y$ .

Let now  $Z = (q_1 \ q_2)^{-1} \omega'_3 Y$ . We want to estimate

$$\|Z - \omega'\|_r = \sup_{\rho: |\rho| \leq r} N^\rho$$

where

$$N^\rho = \sup_{y \in T^3} \sup_{i=1,2,3} |D^\rho Z_i(y) - D^\rho \omega'_i| \quad (*)$$

and  $D^\rho$  denotes a partial differentiation of order  $|\rho|$ . Notice that it suffices to take the first supremum in (\*) over  $y \in h \dot{I}^3$ , i.e.

$y = \Phi x$  where  $x \in g \dot{I}^3$ . We have

$$\frac{\partial}{\partial y} = \begin{pmatrix} q_1 & & & \\ & q_2 & & \\ -p_1 & -p_2 & (q_1 \ q_2)^{-1} & \end{pmatrix} \frac{\partial}{\partial x}$$

so that

$$\sup_i \left| \frac{\partial}{\partial y_i} \cdot \right| < (q_1 + q_2) \sup_i \left| \frac{\partial}{\partial x_i} \cdot \right|$$

Notice also that

$$\begin{aligned} z_i(y) - \omega'_i &= (q_1 q_2)^{-1} \omega'_3 \begin{pmatrix} q_1^{-1} X_1 + p_1 & q_2 \\ q_2^{-1} X_2 + p_2 & q_1 \\ & q_1 & q_2 \end{pmatrix} - \omega'_3 \begin{pmatrix} p_1 & q_1^{-1} \\ p_2 & q_2^{-1} \\ & & 1 \end{pmatrix} \\ &= (q_1 q_2)^{-1} \omega'_3 \begin{pmatrix} q_1^{-1} X_1 \\ q_2^{-1} X_2 \\ 0 \end{pmatrix} \end{aligned}$$

Therefore

$$N^\rho \leq (q_1 q_2)^{-1} \omega'_3 (q_1 + q_2)^{|\rho|} \left( \sup_{i=1,2} q_i^{-1} \right) \sup_{i=1,2} \|X_i\| |\rho|$$

$$\|Z - \omega'\|_r \leq (q_1 q_2)^{-2} (q_1 + q_2)^{r+1} [\omega'_3 \|X\|_r]$$

If we have chosen  $q_1, q_2$  sufficiently large, we have

$$\|Z - \omega'\|_2 < \epsilon/2$$

and therefore  $\|Z - \omega\|_2 < \epsilon$ .

Consider the Poincaré map  $P : T^2 \rightarrow T^2$  defined by the vector field  $Z$  on  $T^3 = T^2 \times T^1$ . By construction the non wandering set of  $P$  contains a Cantor set, and the same is true if  $Z$  is replaced by a

sufficiently close vector field  $Z'$ . This concludes the proof for  $k = 3$ .

In the general case  $k \geq 3$  we approximate again  $\omega$  by  $\omega'$  rational and let

$$0 < \frac{\omega'_i}{\omega'_k} = \frac{p_i}{q_i} < 1 \quad \text{for } i = 1, \dots, k-1$$

We assume that the integers  $p_1 \prod_{i \neq 1} q_i, \dots, p_{k-1} \prod_{i \neq k-i} q_i$  have no common divisor. Furthermore  $q_1, \dots, q_{k-1}$  are chosen sufficiently large and such that

$$\left( \max_i q_i \right) / \left( \min_i q_i \right) < C$$

where  $C$  is a constant depending on  $k$  only.

The rest of the proof goes as for  $k = 2$ , with the horseshoe diffeomorphism replaced by a suitable  $k-1$ -diffeomorphism. In particular, using the diffeomorphism of Fig. 2 (end of § 2) we obtain the following result

Proposition (9.2). Let  $\omega$  be a constant vector field on  $T^k$ ,  $k \geq 4$ . In every  $C^{k-1}$ -small neighbourhood of  $\omega$  there exists an open set of vector fields with a strange attractor.

References.

- [1] R. ABRAHAM and J. MARSDEN. Foundations of Mechanics.  
Benjamin, New York, 1967.
- [2] J. BASS. Fonctions stationnaires. Fonctions de corrélation.  
Application à la représentation spatio-temporelle de la  
turbulence. Ann. Inst. Henri Poincaré. Section B. 5,  
135-193 (1969).
- [3] P. BRUNOVSKY. One-parameter families of diffeomorphisms.  
Symposium on Differential Equations and Dynamical Systems.  
Warwick 1968-69.
- [4] M. HIRSCH, C.C. PUGH, and M. SHUB. Invariant Manifolds. Bull.  
A.M.S. To appear
- [5] M. HIRSCH, C.C. PUGH, and M. SHUB. Invariant Manifolds.  
To appear.
- [6] E. HOPF. Abzweigung einer periodischen Lösung von einer  
stationären Lösung eines Differentialsystems. Ber. Math.-  
Phys. Kl. Sächs. Akad. Wiss. Leipzig 94; 1-22 (1942).
- [7] A. KELLEY. The stable, center-stable, center, center-unstable,  
and unstable manifolds. Published as Appendix C of  
R. Abraham and J. Robbin, Transversal Mappings and Flows,  
Benjamin, New York, 1967.
- [8] L.D. LANDAU and E.M. LIFSHITZ. Fluid Mechanics Pergamon,  
Oxford, 1959.
- [9] J. LERAY. Sur le mouvement d'un liquide visqueux emplissant  
l'espace. Acta mathematica. 63, 193-248 (1934).

- [10] J. MOSER. Perturbation Theory of Quasiperiodic Solutions of Differential Equations. Published in J.B. Keller and S. Antman, Bifurcation Theory and Nonlinear Eigenvalue Problems, Benjamin, New York, 1969.
  
- [11] S. SMALE. Differentiable Dynamical Systems. Bull. Amer. Math. Soc. 73, 747-817 (1967) .
  
- [12] R. THOM. Stabilité Structurelle et Morphogénèse. Benjamin, New York, 1967, to be published.
  
- [13] R.F. WILLIAMS. One-dimensional non-wandering sets. Topology 6 473-487 (1967).