

JOHN F. P. HUDSON
ERIC CHRISTOPHER ZEEMAN
On combinatorial isotopy

Publications mathématiques de l'I.H.É.S., tome 19 (1964), p. 69-94

http://www.numdam.org/item?id=PMIHES_1964__19__69_0

© Publications mathématiques de l'I.H.É.S., 1964, tous droits réservés.

L'accès aux archives de la revue « Publications mathématiques de l'I.H.É.S. » (<http://www.ihes.fr/IHES/Publications/Publications.html>) implique l'accord avec les conditions générales d'utilisation (<http://www.numdam.org/conditions>). Toute utilisation commerciale ou impression systématique est constitutive d'une infraction pénale. Toute copie ou impression de ce fichier doit contenir la présente mention de copyright.

NUMDAM

Article numérisé dans le cadre du programme
Numérisation de documents anciens mathématiques

<http://www.numdam.org/>

ON COMBINATORIAL ISOTOPY

by J. F. P. HUDSON and E. C. ZEEMAN

We define four types of isotopy and show them to be equivalent under suitable conditions of local unknottedness. In particular they are equivalent whenever the codimension is ≥ 3 .

We shall work in the category of polyhedral manifolds and piecewise linear embeddings. All spaces and maps will be in this category unless otherwise stated. By a *polyhedral* (or piecewise linear) manifold M we mean a topological manifold together with a piecewise linearly related family of triangulations; each triangulation is a combinatorial manifold, that is to say a finite or countable simplicial complex in which each closed vertex star is a combinatorial ball. We shall consider embeddings of a *compact* m -manifold M in a q -manifold Q , which may or may not be compact. The manifolds may or may not be bounded; denote by \dot{M} the boundary of M , and by $\overset{\circ}{M}$ the interior of M . An embedding $f: M \rightarrow Q$ is called *proper* if $f^{-1}\dot{Q} = \dot{M}$. In particular if M is closed (compact without boundary) then any embedding of M in the interior of Q is proper. In this paper we shall confine our attention to proper embeddings of M in Q , and the generalisation of the results to non-proper embeddings will be considered in a subsequent paper [2] by one of us.

Definitions of isotopy.

1) By a *homeomorphism* h of M we mean a homeomorphism of M onto itself. In particular h is a proper embedding. If Y is a subset of M such that $h|_Y =$ the identity, then we say h *keeps* Y *fixed*.

2) Let I denote the unit interval. An *isotopy* of M in Q is a proper level preserving embedding $F: M \times I \rightarrow Q \times I$.

Denote by F_t the proper embedding $M \rightarrow Q$ defined by $F(x, t) = (F_t x, t)$, all $x \in M$. The subspace $\bigcup_{t \in I} F_t M$ of Q is called the *track left by* the isotopy. If $Y \subset M$, we say F *keeps* Y *fixed* if $F(x, t) = F(x, 0)$, for all $x \in M$ and $t \in I$.

3) The embeddings $f, g: M \rightarrow Q$ are *isotopic* if there exists an isotopy F of M in Q with $F_0 = f$ and $F_1 = g$.

4) An *ambient isotopy* of Q is a level preserving homeomorphism $H : Q \times I \rightarrow Q \times I$ such that $H_0 =$ the identity, where as above H_t is defined by $H(x, t) = (H_t x, t)$, for all $x \in Q$. We say that H *covers* the isotopy F if the diagram

$$\begin{array}{ccc} Q \times I & & \\ \downarrow F_0 \times 1 & \searrow H & \\ M \times I & & Q \times I \\ & \nearrow F & \end{array}$$

is commutative; in other words $F_t = H_t F_0$, for all $t \in I$.

5) The embeddings $f, g : M \rightarrow Q$ are *ambient isotopic* if there exists an ambient isotopy H of Q such that $H_1 f = g$.

Remark. — If $M = Q$, then a proper embedding $M \times I \rightarrow Q \times I$ is the same as a homeomorphism $Q \times I \rightarrow Q \times I$. Therefore, since we have restricted attention to proper embeddings, the only difference between an isotopy of Q in Q and an ambient isotopy of Q is that the latter has to start with the identity; consequently two homeomorphisms of Q are isotopic if and only if they are ambient isotopic.

6) A homeomorphism or ambient isotopy of Q is said to be *supported* by X if it keeps $Q - X$ fixed. By continuity the frontier $\overline{X} \cap (\overline{Q - X})$ of X in Q must also be kept fixed.

7) An *interior move* of Q is a homeomorphism of Q supported by a ball, keeping the boundary of the ball fixed. A *boundary move* of Q is a homeomorphism of Q supported by a ball that meets \dot{Q} in a face. (A *face* of a q -ball B is a $(q-1)$ -ball in \dot{B}). In a boundary move the complementary face is the frontier that is kept fixed by continuity.

8) The embeddings $f, g : M \rightarrow Q$ are *isotopic by moves* if there is a finite sequence h_1, h_2, \dots, h_n of moves of Q such that $h_1 h_2 \dots h_n f = g$.

9) A *standard interior linear move* is a homeomorphism $\Delta \rightarrow \Delta$ of the standard simplex Δ , defined by mapping $\dot{\Delta}$ by the identity, mapping the barycentre to another interior point, and joining linearly. A *standard boundary linear move* is a homeomorphism $\Delta \rightarrow \Delta$ defined by mapping a vertex to itself, mapping the opposite face by a standard interior linear move, and joining linearly.

10) A *linear move* of Q is a move h supported by a ball B , for which there exists a homeomorphism $k : B \rightarrow \Delta$ such that khk^{-1} is a standard linear move.

11) The embeddings $f, g : M \rightarrow Q$ are *isotopic by linear moves* if there exists a finite sequence h_1, h_2, \dots, h_n of linear moves of Q such that $h_1 h_2 \dots h_n f = g$.

Lemma 1 (Alexander [1]). — *Any homeomorphism of a ball keeping the boundary fixed is isotopic to the identity keeping the boundary fixed.*

Proof. — Since a ball is homeomorphic to a simplex, it suffices to prove the lemma for a simplex Δ . Given $h : \Delta \rightarrow \Delta$, construct $H : \Delta \times I \rightarrow \Delta \times I$ as follows.

Let

$$H(x, t) = \begin{cases} hx, & t = 0, \\ x, & t = 1 \text{ or } x \in \dot{\Delta}. \end{cases}$$

This defines a level preserving homeomorphism of the boundary of the prism $\Delta \times I$; complete the definition of H by mapping the centre of the prism to itself, and joining linearly to the boundary. The resulting homeomorphism is also level preserving and piecewise linear, and so is an isotopy from h to the identity.

Corollary. — Any homeomorphism of a ball keeping a face fixed is isotopic to the identity keeping the face fixed.

Proof. — Let Δ be an n -simplex, v a vertex, and Γ the opposite face. Given an n -ball and a face, then there is a homeomorphism of the ball onto Δ throwing the face onto $v\dot{\Gamma}$. Therefore it suffices to prove the Corollary for the special case of a homeomorphism h of Δ keeping $v\Gamma$ fixed. Since $h|_{\Gamma}$ keeps $\dot{\Gamma}$ fixed, the lemma gives an isotopy G , say, of Γ keeping $\dot{\Gamma}$ fixed from $h|_{\Gamma}$ to the identity. Define H on the boundary of the prism $\Delta \times I$ by

$$H(x, t) = \begin{cases} hx, & t=0, \\ x, & t=1 \text{ or } x \in v\dot{\Gamma}, \\ G(x, t), & x \in \Gamma. \end{cases}$$

Then extend H to the prism as in the lemma.

Description of results.

Using Lemma 1 and its Corollary, we can deduce at once that:

$$\begin{array}{c} f, g \text{ isotopic by linear moves} \\ \downarrow (3) \\ f, g \text{ isotopic by moves} \\ \downarrow (1) \\ f, g \text{ ambient isotopic} \\ \downarrow (2) \\ f, g \text{ isotopic.} \end{array}$$

Our purpose is to show in Theorems 1, 2 and 3 that the arrows 1), 2) and 3) can be reversed. Therefore all four definitions are equivalent. At the top we have the elementary intuitive idea of pushing the vertices of a complex around Euclidean space; at the bottom is the definition of isotopy natural to the category.

To prove step 2), the covering isotopy theorem, it is obviously necessary to impose a local unknottedness condition on the isotopy. For otherwise the knots of classical knot theory give counterexamples of embeddings that are mutually isotopic but not ambient isotopic. However, as we shall see, this phenomenon occurs only in codimension 2, and possibly in codimension 1.

Question. — Can we extend the equivalence further? For instance can we drop the level preserving condition? More precisely, call two maps pseudo-isotopic if they are isotopic by an « isotopy » that is level preserving for $t=0, 1$ but not necessarily

for $0 < t < 1$. In codimension 2 pseudo-isotopy is essentially weaker than isotopy, because for example slice knots can be unknotted by a smooth pseudo-isotopy. But is pseudo-isotopy equivalent to isotopy in codimension ≥ 3 ?

Local unknottedness.

A *ball pair* (B^q, B^m) , $q > m$, is a pair of balls with $B^m \subset B^q$ properly. A ball pair is *unknotted* if it is homeomorphic to the standard pair $(\Sigma\Delta, \Delta)$, where Δ denotes the standard m -simplex and Σ denotes $(q-m)$ -fold suspension.

Given a proper embedding $f: M \rightarrow Q$ between manifolds, we say f is *locally unknotted* if, for some (and therefore for any) triangulations K, L of M, Q such that $f: K \rightarrow L$ is simplicial, the ⁽¹⁾ball pair

$$(\overline{\text{st}}(fv, L), f(\overline{\text{st}}(v, K)))$$

is unknotted for each vertex $v \in K$. If f is locally unknotted then so is the restriction of f to the boundaries $f: \dot{M} \rightarrow \dot{Q}$ (see [4, Corollary 5]).

We say that an isotopy $F: M \times I \rightarrow Q \times I$ is a *locally unknotted isotopy* if

- (i) each level $F_t: M \rightarrow Q$ is a locally unknotted embedding, and
- (ii) for each subinterval $J \subset I$, the restriction $F: M \times J \rightarrow Q \times J$ is a locally unknotted embedding. If F is a locally unknotted isotopy, then so is the restriction to the boundaries $F: \dot{M} \times I \rightarrow \dot{Q} \times I$ (see again [4, Corollary 5]).

Lemma 2 (Zeeman [8]). — *Any ball pair of codimension ≥ 3 is unknotted.*

Corollary. — *Any proper embedding or isotopy of manifolds of codimension ≥ 3 is locally unknotted.*

Knots exist in codimension 2, and possibly in codimension 1, depending upon the unsolved state of the combinatorial Schönflies conjecture. Therefore when we say “locally unknotted” in future we refer only to the cases of codimension 1 or 2.

Remark. — The above definition of locally unknotted isotopy is tailored to our needs. There is an alternative definition of a locally trivial isotopy as follows (see [3]). An isotopy $F: M \times I \rightarrow Q \times I$ is *locally trivial* if, for each $(x, t) \in M \times I$ there exists an m -ball neighbourhood A of x in M and an interval neighbourhood J of t in I , and a commutative diagram

$$\begin{array}{ccc} A \times J & \xrightarrow{c} & \Sigma A \times J \\ \downarrow c & & \downarrow g \\ M \times I & \xrightarrow{F} & Q \times I \end{array}$$

⁽¹⁾ We use the notation $\text{st}(v, K)$ for the open star of a vertex v in a complex K , and $\overline{\text{st}}(v, K)$ for the closed star. If K is a combinatorial m -manifold then the closed star is an m -ball.

where Σ denotes $(q-m)$ -fold suspension, and G is a level preserving embedding onto a neighbourhood of $F(x, t)$. It is easy to verify that

$$\begin{array}{c} F \text{ is a locally trivial isotopy} \\ \Downarrow (1) \\ F \text{ is a locally unknotted isotopy} \\ \Downarrow (2) \\ F \text{ is an isotopy and a locally unknotted embedding.} \end{array}$$

It is an immediate corollary of Theorem 2 and Addendum 2.1 below that the arrow (1) can be reversed. Therefore a locally trivial isotopy is the same as a locally unknotted isotopy. We conjecture that the arrow (2) can also be reversed; it is a problem involving the unique factorisation of higher dimensional sphere knots of codimension 2, which is another unsolved problem (see [4]).

Statement of the Theorems.

Theorem 1. — *Let h be a homeomorphism of Q isotopic to the identity by an isotopy with compact support keeping a subset Y fixed. Then h can be expressed as the product of a finite number of moves keeping Y fixed.*

Addendum 1.1. — *Given an arbitrary triangulation of Q , we can choose the moves to be supported by the vertex stars. Therefore the moves can be made arbitrarily small.*

Addendum 1.2. — *Let H be an ambient isotopy of Q (not necessarily with compact support) and let X be a compact subset of Q . Then there is a finite product h of moves such that $H_1|X = h|X$.*

Corollary 1.3. — *The following three conditions between embeddings of a compact manifold M in Q are equivalent :*

- (i) *ambient isotopic ;*
- (ii) *ambient isotopic by an ambient isotopy with compact support ;*
- (iii) *isotopic by moves.*

Remark. — For Corollary 1.3 it is not necessary that the embeddings be either proper or locally unknotted. In fact the corollary is true not only for embeddings but for arbitrary maps $M \rightarrow Q$.

Corollary 1.4. — *Let M be compact, let $f : M \rightarrow Q$ be a proper locally unknotted embedding, and let g be a homeomorphism of M that is isotopic to identity keeping \dot{M} fixed. Then g can be covered by a homeomorphism h of Q keeping \dot{Q} fixed; in other words the diagram is commutative :*

$$\begin{array}{ccc} Q & \xrightarrow{h} & Q \\ t \uparrow & & t \uparrow \\ M & \xrightarrow{g} & M \end{array}$$

Remark. — In fact Corollary 1.4 is improved by Theorem 2, to the extent of covering not only the homeomorphism but the whole isotopy. However we need to use Corollary 1.4 in the proof of Theorem 5, in the course of proving Theorem 2.

Theorem 2 (Covering isotopy theorem). — Let M be compact, and let $F : M \times I \rightarrow Q \times I$ be a locally unknotted isotopy keeping \dot{M} fixed, and let N be a neighbourhood of the track left by the isotopy. Then F can be covered by an ambient isotopy of Q supported by N keeping \dot{Q} fixed.

Addendum 2.1. — Conversely if F_0 is locally unknotted and F can be covered by an ambient isotopy then F is locally unknotted and locally trivial.

Addendum 2.2. — Let X be a compact subset of \dot{Q} , and N a neighbourhood of X in Q . Then an ambient isotopy of \dot{Q} supported by X can be extended to an ambient isotopy of Q supported by N .

Corollary 2.3. — Theorem 2 remains true if the words “keeping \dot{M} fixed” are omitted from the hypothesis and “keeping \dot{Q} fixed” from the thesis.

Corollary 2.4. — If the codimension is ≥ 3 , then any isotopy of M in Q can be covered by an ambient isotopy of Q .

Remark. — The covering isotopy theorem can be generalised by replacing the unit interval I by a simplex Δ of arbitrary dimension (see a subsequent paper by one of us [3]). The statement is as follows. Let o denote the first vertex of Δ . Given a proper locally trivial embedding F such that the diagram

$$\begin{array}{ccc} M \times \Delta & \xrightarrow{F} & Q \times \Delta \\ \pi \searrow & & \swarrow \pi \\ & \Delta & \end{array}$$

is commutative, where π denotes projection onto the second factor, then there exists a homeomorphism H such that the diagram

$$\begin{array}{ccc} Q \times \Delta & \xrightarrow{H} & Q \times \Delta \\ \pi \searrow & & \swarrow \pi \\ & \Delta & \end{array}$$

is commutative, $H_0 = I$ and $F_t = H_t F_0$ all $t \in \Delta$, where F_t, H_t are defined by

$$F(x, t) = (F_t x, t), \quad H(y, t) = (H_t y, t) \quad \text{all } x \in M, y \in Q, t \in \Delta.$$

The proof is a generalisation of the proof of Theorem 2, and the main idea is the use of collars, as in Lemma 8 below.

Theorem 3. — Let M be compact and let $f, g : M \rightarrow Q$ be proper embeddings that are locally unknotted and ambient isotopic. If the codimension is > 0 , then f, g are isotopic by linear moves.

Corollary 3.1. — If M is compact and the codimension ≥ 3 , then the four definitions of isotopy are equivalent.

Remark 1. — Notice the restriction codimension > 0 that occurs in Theorem 3, but not in Theorem 1 nor in Corollary 1.3. Our proof of Theorem 3 breaks down when $M=Q$, and leaves unsolved the question: *is a homeomorphism of a ball that keeps the boundary fixed isotopic to the identity by linear moves?* Possibly the answer is no, due to an obstruction. Recent results of Kuiper [5] indicate that such an obstruction might be related to the obstructions to smoothing manifolds.

Remark 2. — We have phrased our theorems in *polyhedral* rather than *combinatorial* terms, because we are working in the polyhedral category. In other words we have assumed the embeddings to be piecewise linear, but without reference to any specific triangulations of either of the manifolds concerned. Of course it is impossible to define any useful form of isotopy by linear maps between fixed triangulations of *both* M and Q , because this has the effect of trapping M locally, and preventing the movement of any simplex of M across the boundary of any simplex of Q . This basic error of definition can be found for example in [6, page 17] or [7, page 227]. The error arises from generalising the special case of when Q is Euclidean space, for which there is a more combinatorial notion of isotopy by virtue of the *linear* structure of Euclidean space. The manifold M is given a fixed triangulation, K say, and the isotopy is defined by moving the vertices of K . At each moment the embedding of M is determined by the positions of the vertices of K , and by the linear structure of Euclidean space. Under our hypothesis Q has only a *piecewise linear* structure, not a linear structure, and so the positions of the vertices of K do not determine a unique embedding of M . However, our proof of Theorem 3 does furnish a much stronger statement in terms of moves that are linear with respect to a fixed triangulation K of M , which we now state. For simplicity of statement we assume M closed, although the technique can be adapted to include the bounded case.

Linear moves with respect to a triangulation.

Let Δ^q be the standard q -simplex, and Δ^m an m -dimensional face, $q > m$. Let x be the barycentre of Δ^q , and y a point between x and the barycentre of Δ^m . Let $\sigma : \Delta^q \rightarrow \Delta^q$ be the standard interior linear move throwing x to y .

Let M be closed, let K be a triangulation of M , and let f, g be proper embeddings $M \rightarrow Q$. We say there is a *move from f to g that is linear with respect to K* if the following occurs :

There is a closed vertex star of K , $A = \overline{\text{st}}(v, K)$ say, and a q -ball $B \subset Q$, and a homeomorphism $h : B \rightarrow \Delta^q$ such that

- (i) f, g agree on $K - \overset{\circ}{A}$,
- (ii) $A = f^{-1}B = g^{-1}B$,
- (iii) the composition hf maps the link of v in K homeomorphically onto $\overset{\circ}{\Delta}^m$, maps v to x , and maps A by joining linearly,
- (iv) $g|A = h^{-1}\sigma h(f|A)$.

We leave the analogous definition for the bounded case to the reader.

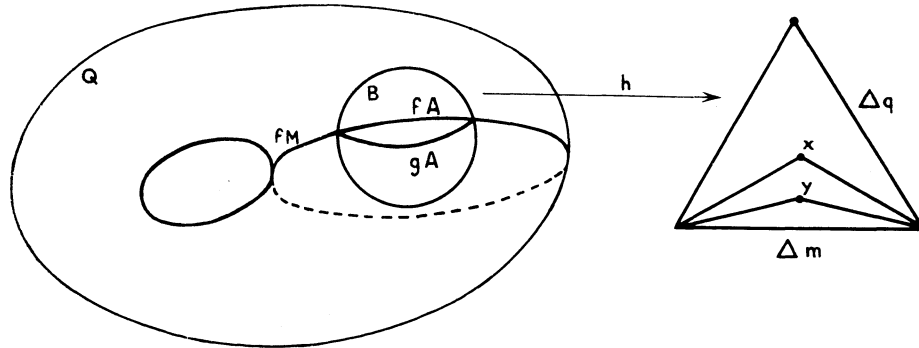

Addendum 3.2. — Let M be closed, and let K be an arbitrary fixed triangulation of M . Let $f, g : M \rightarrow Q$ be proper embeddings that are locally unknotted and ambient isotopic. If codimension > 0 , then f, g are isotopic by interior moves that are linear with respect to K .

The addendum becomes surprising if we imagine embeddings of a 2-sphere in a manifold, and choose K to be the boundary of a 3-simplex, with exactly 4 vertices. Then we can move from any embedding to any other isotopic embedding by assiduously shifting just those 4 vertices linearly back and forth. All the work is secretly done by judicious choice of the balls, or local coordinate systems in the receiving manifold, in which the moves are made.

The rest of the paper consists of the proofs of the above theorems in the order stated.

Proof of Theorem 1.

We are given an ambient isotopy $H : Q \times I \rightarrow Q \times I$ with compact support, and have to show that H_1 is a composition of moves. We first prove the theorem for the case when Q is a compact combinatorial manifold, that is to say Q has a fixed triangulation and is embedded as a finite simplicial complex in some Euclidean space E^n . Then $Q \times I$ is a cell complex in $E^n \times I$. We regard E^n as *horizontal* and I as *vertical*.

Let K, L be subdivisions of $Q \times I$ such that $H : K \rightarrow L$ is simplicial (in fact a simplicial isomorphism). Let A be a principal simplex of L , and B a vertical line element in A . Define $\theta(A)$ to be the angle between $H^{-1}(B)$ and the vertical. Since $H : K \rightarrow L$ is simplicial, this does not depend upon the choice of B . Since H is level preserving, $\theta(A) < \frac{\pi}{2}$. Define $\theta = \max \theta(A)$, the maximum taken over all principal simplexes of L . Then $\theta < \frac{\pi}{2}$.

Now let \mathfrak{S} denote the set of all linear maps $Q \rightarrow I$ (i.e. maps that map each simplex of Q linearly into the unit interval I). Let

$$\mathfrak{S}_\delta = \{f \in \mathfrak{S}; \max f - \min f < \delta\}.$$

If $f \in \mathfrak{S}$, denote by f^* the graph of f , given by

$$f^* = I \times f : Q \rightarrow Q \times I.$$

Then f^* maps each simplex of Q linearly into $E^n \times I$. Let $\varphi(f)$ be the maximum angle that any simplex of f^*Q makes with the horizontal. Given $\varepsilon > 0$, there exists $\delta > 0$, such that if $f \in \mathfrak{S}_\delta$ then $\varphi(f) < \varepsilon$, for choose δ sufficiently small compared with 1-simplices of Q . Choose $\varepsilon < \frac{\pi}{2} - \theta$, and choose δ accordingly.

Now let f be a map in \mathfrak{S}_δ , and let q be a point of Q . Consider the intersection of the arc $H^{-1}(q \times I)$ with f^*Q ; we claim there is exactly one intersection.

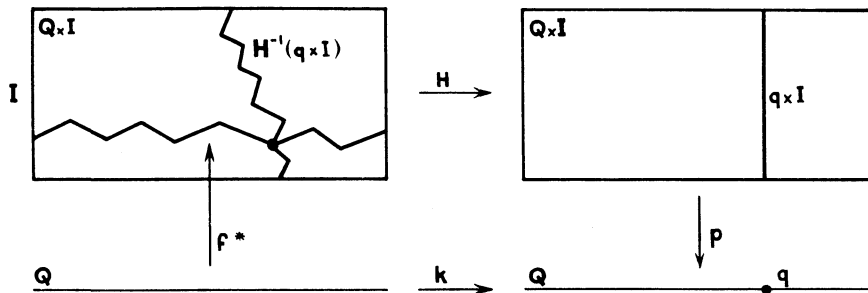

For since f^* is a graph, f^*Q separates the complement $Q \times I - f^*Q$ into points above and below the graph. If there were no intersection, then the arc would connect the below-point $H^{-1}(q, 0)$ to the above-point $H^{-1}(q, 1)$, contradicting their separation. At each intersection, since $\varphi(f) + \theta < \frac{\pi}{2}$, the arc, oriented by I , passes from below to above. Hence there can be at most one intersection.

Let $p : Q \times I \rightarrow Q$ denote the projection onto the first factor. Then

$$k = p H f^* : Q \rightarrow Q$$

is a 1-1 map by the above claim, and so is a piecewise linear homeomorphism of Q . By the compactness of Q and I , choose a sequence of maps f_0, f_1, \dots, f_n in \mathfrak{S}_δ , such that $f_0(Q) = 0, f_n(Q) = 1$, and for each i, f_{i-1} and f_i agree on all but one, v_i say, of the vertices of Q . Define $k_i = p H f_i^*$. Then $k_0 = H_0 =$ the identity, and $k_n = H_1$. Define $h_i = k_i k_{i-1}^{-1}$. Then h_i is a homeomorphism of Q supported by the ball $k_i(\text{st}(v_i, Q))$, keeping $k_i(\text{lk}(v_i, Q))$ fixed, and so is a move. Therefore $H_1 = h_n h_{n-1} \dots h_1$, which is a composition of moves.

If H keeps Y fixed, then $H_t|Y = H_0|Y$ for all $t \in I$, and so $k_i|Y = k_0|Y$. Therefore $h_i|Y =$ the identity for each i ; in other words the moves keep Y fixed. This concludes the proof for the special case when Q is finite simplicial complex in Euclidean space.

If Q is compact, let $K \rightarrow Q$ be a triangulation; we have proved the theorem for K , and therefore it follows for Q .

Suppose now that Q is not compact, but the isotopy has compact support X . Let N be a regular neighbourhood of X in Q , and let Y_0 be the frontier of N in Q . Then the ambient isotopy of Q restricts to an ambient isotopy of the compact manifold N keeping Y_0 fixed, and so by what we have already proved, $H_1|_N$ is a composition of moves of N keeping Y_0 fixed. The moves can be extended by the identity to moves of Q . If H keeps Y fixed, then the moves of N keep $N \cap Y$ fixed, and so the extended moves of Q keep Y fixed. The proof of Theorem 1 is complete.

Proof of Addendum 1.1.

Suppose we are given a triangulation $K \rightarrow Q$; we have to show that the moves can be chosen so as to be supported by the vertex stars of K . Since the moves are already supported by the compact support of the isotopy, it suffices to consider the case when Q is compact, and so K is a finite complex. Let β denote the covering of $Q \times I$ by open sets

$$\beta = \{st(w, K) \times I; w \in K\},$$

where w runs over the vertices of K . Let λ be the Lebesgue number of the open covering $H^{-1}\beta$ of $Q \times I$. Choose a subdivision K' of K such that the mesh of the star covering of K' is less than $\lambda/2$. In the above proof of Theorem 1 use K' instead of Q , and choose δ with additional restriction that $\delta < \lambda/2$.

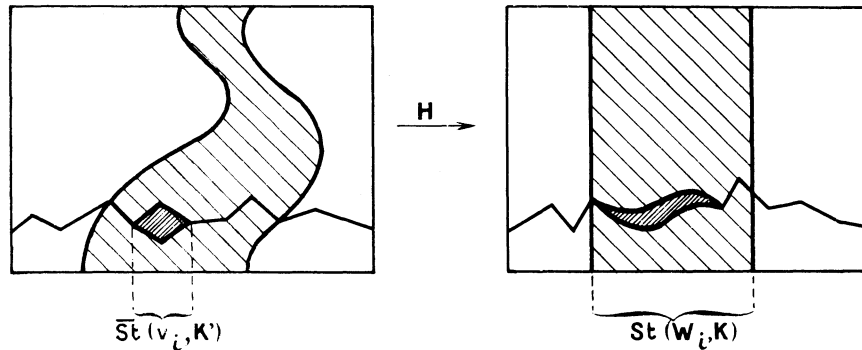

Continuing with the same notation as in the proof of Theorem 1, for each i , the ball $f_i^*(\overline{st}(v_i, K'))$ is of diameter less than λ , and so is contained in $H^{-1}(st(w_i, K) \times I)$ for some vertex $w_i \in K$. Therefore the move h_i is supported by

$$\begin{aligned} h_i(\overline{st}(v_i, K')) &= p H f_i^*(\overline{st}(v_i, K')) \\ &\subset p(st(w_i, K) \times I) \\ &= st(w_i, K). \end{aligned}$$

In other words each move is supported by a vertex star of K .

Proof of Addendum 1.2.

We are given an ambient isotopy H (not necessarily with compact support) and a compact subset X of Q . We have to find a product h of moves such that $H_1|X = h|X$.

Choose a triangulation of Q — call it by the same name — and let Y be the smallest subcomplex containing X , and Z the simplicial neighbourhood of Y in Q . Then Z is a finite subcomplex of Q , because X is compact.

Fix t_0 for the moment, $0 \leq t_0 \leq 1$. Let \mathfrak{F} be the set of linear maps $f: Q \rightarrow I$ such that $f(Q-Z) = t_0$. In particular let $f_t \in \mathfrak{F}$ denote the map determined by the vertex map

$$f_t v = \begin{cases} t, & v \in Y, \\ t_0, & v \notin Y. \end{cases}$$

Since each map in \mathfrak{F} is determined by the image of the finite subcomplex Z , we avoid the non-compactness of Q , and can apply the machinery of the proof of Theorem 1 to find \mathfrak{F}_δ such that if $f \in \mathfrak{F}_\delta$ then

$$k = \rho H f^* : Q \rightarrow Q$$

is a homeomorphism. Let J be the δ -neighbourhood of t_0 in I . If $s, t \in J$, then $f_s, f_t \in \mathfrak{F}_\delta$, and the corresponding k_s, k_t are homeomorphisms of Q . By the proof of Theorem 1, the composition $h = k_t k_s^{-1}$ is a finite product of moves. But by construction $k_t|X = H_t|X$, and the same for s , and so $H_t H_s^{-1}|H_s X = h|H_s X$.

Now consider the pairs (s, t) , $0 \leq s < t \leq 1$, for which the following statement is true: there is a finite product of moves h , such that $H_t H_s^{-1}|H_s X = h|H_s X$. We have shown it to be true locally. If it is true for (r, s) and (s, t) then it is true for (r, t) by composition. Therefore by the compactness of I it is true globally, and in particular for $(0, 1)$. Since $H_0 = 1$, this is what we want to prove, $H_1|X = h|X$.

Proof of Corollary 1.3.

We have to show the equivalence of (i) ambient isotopic, (ii) ambient isotopic by an ambient isotopy with compact support, and (iii) isotopic by moves. (ii) implies (i) a fortiori. (i) implies (iii) by Addendum 1.2, for choose $X = fM$. Finally (iii) implies (ii) by Lemma 1 and its Corollary.

Proof of Corollary 1.4.

Given an embedding $f: M \rightarrow Q$, the problem is to cover a homeomorphism g of M by a homeomorphism h of Q . Choose triangulations of M, Q — call them by the same names — such that f is simplicial. We are given that g is isotopic to the identity, and so by Addendum 1.1 we can write g as a composition of moves supported by vertex stars :

$$g = g_1 g_2 \dots g_n,$$

where g_i is supported, say, by the ball $B_i^m = \overline{\text{st}}(v_i, M)$, $v_i \in M$. Let $B_i^q = \overline{\text{st}}(fv_i, Q)$. Then the ball pair (B_i^q, fB_i^m) is unknotted, because f is locally unknotted by hypothesis.

Therefore the homeomorphism $fg_i f^{-1}$ of the smaller ball can be suspended to a homeomorphism, h_i say, of the larger ball. Since g keeps \dot{M} fixed by hypothesis, the move g_i keeps \dot{B}_i^m fixed, for each i . Therefore the suspended homeomorphism h of the larger ball keeps \dot{B}_i^q fixed, and can be extended by the identity to a move h_i of Q . The composition $h = h_1 h_2 \dots h_n$ covers g and keeps \dot{Q} fixed.

The proof of Theorem 1 and its addenda and corollaries is complete.

Collars.

Before proving Theorem 2, we first need to prove a couple of theorems about collars of compact manifolds. The theorems can be generalised to non-compact manifolds, but since we only need the compact versions, we content ourselves with the latter because the proofs are simpler.

Let M be a compact manifold; define a *collar* of M to be an embedding

$$c : \dot{M} \times I \rightarrow M$$

such that $c(x, 0) = x$ for all $x \in \dot{M}$.

Lemma 3. — *Any compact manifold has a collar.*

A proof is given, for example, in [8, Theorem 3].

Given a collar c of M , and given $0 < \varepsilon < 1$, define the *shortened collar* $c_\varepsilon : \dot{M} \times I \rightarrow M$ by the formula $c_\varepsilon(x, t) = c(x, \varepsilon t)$, for all $x \in \dot{M}$ and $t \in I$.

Lemma 4. — *The collars c, c_ε are ambient isotopic keeping \dot{M} fixed.*

Proof. — First lengthen the collar c as follows. The image of c is a submanifold of M of the same dimension, and so the closure of the complement is also a submanifold, with boundary $c(\dot{M} \times I)$. Therefore the latter has a collar by Lemma 3, which we can *add* to c to give a collar, d say, of M such that $c = d_{\frac{1}{2}}$. Therefore $c_\varepsilon = d_{\varepsilon/2}$.

Let $g : I \rightarrow I$ be the (piecewise linear) homeomorphism that maps $[0, \frac{1}{2}]$, $[\frac{1}{2}, 1]$ linearly onto $[0, \varepsilon/2]$, $[\varepsilon/2, 1]$, respectively. Then g is ambient isotopic to the identity by an ambient isotopy, G say, keeping \dot{I} fixed. Let $I \times G$ denote the product ambient isotopy of $\dot{M} \times I$, and let H denote the image of $I \times G$ under d ; since $I \times G$ keeps $\dot{M} \times \dot{I}$ fixed, we can extend H by the identity to an ambient isotopy H of M keeping \dot{M} fixed. If $x \in \dot{M}$ and $t \in I$, then by construction

$$\begin{aligned} H_1 c(x, t) &= H_1 d(x, t/2) \\ &= d(x, G_1(t/2)) \\ &= d(x, \varepsilon t/2) \\ &= c_\varepsilon(x, t). \end{aligned}$$

Therefore $H_1 c = c_\varepsilon$, and the lemma is proved.

In Theorem 4 we shall improve upon Lemma 4 and show that *any* two collars are ambient isotopic. But first it is necessary to prove a couple of technical lemmas

about constructing isotopies. Lemma 5 is about isotoping a homeomorphism which is not level preserving into one which is level preserving over a small subinterval. Lemma 6 is about two isotopies which are themselves isotopic. In both lemmas we have to be careful that the constructed isotopies are piecewise linear, and not merely piecewise algebraic (as for example in [6, page 14]).

Notation. — Let I_ε denote the interval $[0, \varepsilon]$, where $0 < \varepsilon \leq 1$.

Lemma 5. — *Let X be a compact polyhedron, and $f : X \times I_\varepsilon \rightarrow X \times I$ an embedding such that $f|_{X \times 0}$ is the identity. Then there exists δ , $0 < \delta < \varepsilon$, and an embedding $g : X \times I_\varepsilon \rightarrow X \times I$ such that :*

- (i) g is level preserving in I_δ .
- (ii) g is ambient isotopic to f keeping $X \times \dot{I}$ fixed.
- (iii) If Y is a subpolyhedron of X such that $f|_{Y \times I_\varepsilon}$ is already level preserving, then we can choose g to agree with f on $Y \times I_\varepsilon$ and the ambient isotopy to keep $f(Y \times I_\varepsilon)$ fixed.

Proof. — Let K, L be triangulations of $X \times I_\varepsilon, X \times I$ such that $f : K \rightarrow L$ is simplicial (in fact a simplicial embedding). Choose δ , $0 < \delta < \varepsilon$, so small that no vertices of K or L lie in the interval $0 < t \leq \delta$. This is possible because K, L are finite complexes, since X is compact. Choose first derived complexes K_1, L_1 of K, L according to the rule: if the interior of a simplex meets the level $X \times \delta$ then star the simplex at a point on $X \times \delta$; otherwise star it barycentrically (the derived complex is formed by starring all the simplexes in some order of decreasing dimension). Let $g : K_1 \rightarrow L_1$ be the derived map of f . Notice that f, g agree on any simplex not meeting the level $X \times \delta$; if a simplex of K does meet the level $X \times \delta$, then, although it has the same image under f, g setwise, the two maps of the simplex in general will differ pointwise. We verify the three properties.

Property (i) holds because by construction g is level preserving at the levels 0 and δ , and any point in between these two levels lies on a unique interval that is mapped linearly onto another interval, both intervals beginning (at the same point) in $X \times 0$ and ending in $X \times \delta$.

To prove property (ii) define another first derived complex L_2 of L by the rule : if a simplex of L lies in fK then star it so that $f : K_1 \rightarrow L_2$ is simplicial; otherwise star it barycentrically. Then the derived map $K_1 \rightarrow L_2$ is the same as f . Now the isomorphism $L_2 \rightarrow L_1$ between two first derived complexes is ambient isotopic to the identity as follows. (The obvious isotopy by straight paths in the simplexes of L is no good because it is piecewise algebraic and ⁽¹⁾ not piecewise linear.) The isotopy H is constructed inductively on the prisms $B \times I$, where B runs over the simplexes of L

(¹) For example consider the ambient isotopy H of I given by the family $H_t : I \rightarrow I$ of piecewise linear maps, where H_t maps the intervals $[0, \frac{1}{3}]$, $[\frac{1}{3}, 1]$ linearly onto $[0, \frac{1+t}{3}]$, $[\frac{1+t}{3}, 1]$, respectively. In other words H is the obvious isotopy by straight paths from $H_0 = \text{id}$ to H_1 . But although each H_t is piecewise linear, H itself is not, only piecewise algebraic, because for example the line segment $3s = t + t^2$.

in some order of increasing dimension. H is already defined on the boundary of the prism, for $H|_{\dot{B} \times I}$ is given by induction, $H|_{B \times I}$ by the isomorphism, and $H|_{B \times 0}$ by the identity; map the centre of the prism to itself, and join linearly to the boundary. The isotopy keeps fixed any subcomplex of L on which L_1 and L_2 agree. Therefore H moves f to g keeping $X \times \dot{I}$ fixed.

To prove property (iii) we put extra conditions on the choices of K and L_1 . Choose K so as to contain $Y \times I_e$ as a subcomplex. Having chosen K , K_1 , and therefore L_2 , then choose L_1 so as to agree with L_2 on $f(Y \times I_e)$, this being compatible with the condition of starring on the δ level, because $f|_{Y \times I_e}$ is already level preserving. Therefore H keeps $f(Y \times I_e)$ fixed.

Lemma 6. — *Let $g : X \times I \rightarrow X \times I$ be an ambient isotopy of a polyhedron X . Let h be the ambient isotopy of X defined by*

$$h_t = \begin{cases} I, & 0 \leq t \leq \frac{1}{2}, \\ g_{2t-1}, & \frac{1}{2} \leq t \leq 1. \end{cases}$$

Then g, h are ambient isotopic keeping $X \times \dot{I}$ fixed.

Proof. — Triangulate the square I^2 as shown, and let $u : I^2 \rightarrow I$ be the simplicial map determined by mapping the vertices to 0 or 1 as shown.

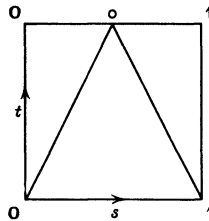

Define $G : (X \times I) \times I \rightarrow (X \times I) \times I$ by

$$G((x, s), t) = ((g_{u(s,t)}x, s), t).$$

Then (i) G is a level preserving homeomorphism by definition.

(ii) A map is piecewise linear if and only if its graph is a polyhedron.

G is piecewise linear, because the graph ΓG of G is the intersection of two subpolyhedra of $(X \times I^2)^2$:

$$\Gamma G = ((I \times u)^2)^{-1} \Gamma g \cap (X^2 \times \Gamma i),$$

where $(I \times u)^2$ denotes the map $(X \times I^2)^2 \rightarrow (X \times I)^2$, where Γg is the graph of g , and Γi the graph of the identity i on I^2 .

Therefore G is an isotopy of $X \times I$ in itself. By the construction of u , G moves g to h and keeps $X \times \dot{I}$ fixed. Therefore $G(g^{-1} \times I)$ is an ambient isotopy moving g to h keeping $X \times \dot{I}$ fixed.

Theorem 4. — *If M is compact, then any two collars of M are ambient isotopic keeping \dot{M} fixed.*

Proof. — Given two collars, the idea is to (i) ambient isotope one of them until it is level preserving relative to the other on a small interval, (ii) isotope it further until it agrees with the other on a smaller interval, and then (iii) isotope both onto this common shortened collar.

Let $c, d : \dot{M} \times I \rightarrow M$ be the two given collars. Since each maps onto a neighbourhood of \dot{M} in M , we can choose $\varepsilon > 0$, such that $c(\dot{M} \times I_\varepsilon) \subset d(\dot{M} \times I)$. Since c, d are embeddings, we can factor $c = df$, where f is an embedding such that the diagram

$$\begin{array}{ccc} \dot{M} \times I_\varepsilon & \xrightarrow{c} & M \\ \downarrow f & \searrow d & \\ \dot{M} \times I & \xrightarrow{d} & M \end{array}$$

is commutative and $f|_{\dot{M} \times 0}$ is the identity.

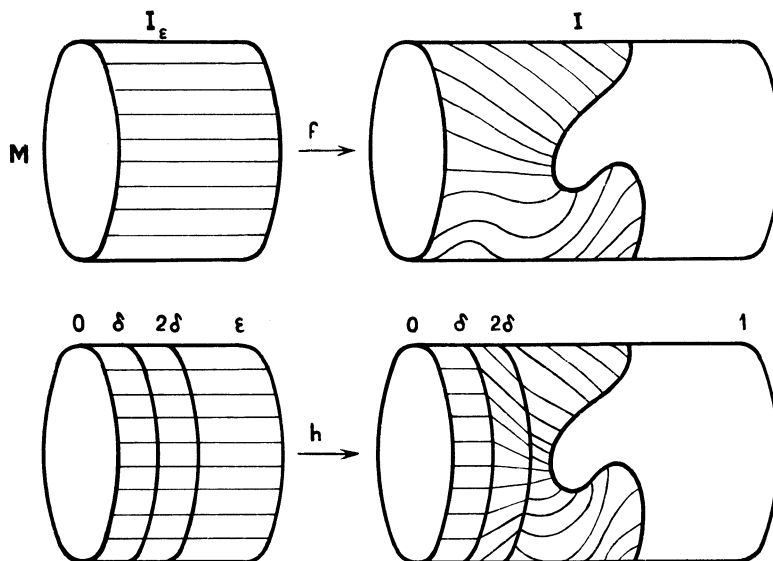

By Lemma 5 there exists $\delta, 0 < 2\delta < \varepsilon$, and an ambient isotopy F of $\dot{M} \times I$ moving f to g , say, keeping $\dot{M} \times \dot{I}$ fixed, and such that g is level preserving for $0 \leq t \leq 2\delta$. The reason for making g level preserving is that we can now apply Lemma 6 to $g|_{\dot{M} \times I_{2\delta}}$, and obtain an ambient isotopy G of $\dot{M} \times I_{2\delta}$ moving $g|_{\dot{M} \times I_{2\delta}}$ to h , say, keeping $\dot{M} \times \dot{I}_{2\delta}$ fixed, and such that h is the identity for $0 \leq t \leq \delta$. Extend h to an embedding $h : \dot{M} \times I_\varepsilon \rightarrow \dot{M} \times I$ by making it agree with g outside $\dot{M} \times I_{2\delta}$, and extend G by the identity to an ambient isotopy of $\dot{M} \times I$.

Then GF is an ambient isotopy moving f to h keeping $\dot{M} \times \dot{I}$ fixed. Let H be the image of GF under d . Since GF keeps $\dot{M} \times I$ fixed, we can extend H by the identity to an ambient isotopy H of M keeping \dot{M} fixed. Let $e = H_1 c$. Then e is a collar that is ambient isotopic to c and agrees with the beginning of d , because if $x \in \dot{M}$ and $t \in I$ then

$$\begin{aligned} e_\delta(x, t) &= e(x, \delta t) \\ &= H_1 c(x, \delta t) \\ &= dG_1 F_1 d^{-1} c(x, \delta t) \\ &= dG_1 F_1 f(x, \delta t) \\ &= dh(x, \delta t) \\ &= d(x, \delta t) \\ &= d_\delta(x, t). \end{aligned}$$

Therefore $e_\delta = d_\delta$, and so by Lemma 4 there is a sequence of ambient isotopic collars : $c, e, e_\delta = d_\delta, d$. The proof of Theorem 4 is complete.

Compatible collars.

So far we have only considered collars on a single manifold; we now consider pairs of manifolds. Let $f : M \rightarrow Q$ be a proper locally unknotted embedding between two compact manifolds. Define two collars c, d of M, Q to be *compatible* with f if the diagram

$$\begin{array}{ccc} \dot{Q} \times I & \xrightarrow{d} & Q \\ \uparrow f \times 1 & & \uparrow f \\ \dot{M} \times I & \xrightarrow{c} & M \end{array}$$

is commutative, and $\text{im } d \cap \text{im } f = \text{im } fc$.

Lemma 7. — *Given a proper locally unknotted embedding between compact manifolds then there exist compatible collars.*

For the proof see [8, Theorem 3 and Corollary]. The proof is a straightforward labour of constructing the collars inductively on the boundary simplexes of some triangulation of the manifolds, in some order of increasing dimension.

We now improve Lemma 7 to the extent of transferring the smaller collar from the thesis to the hypothesis.

Theorem 5. — *Given a proper locally unknotted embedding $f : M \rightarrow Q$ between compact manifolds, and a collar c of M , then there exists a compatible collar d of Q .*

Proof. — Lemma 7 furnishes compatible collars, c^*, d^* say, of M, Q . By Theorem 4 there exist an ambient isotopy G of M keeping \dot{M} fixed, such that $G_1 c^* = c$. By

Corollary 1.4 we can cover G_1 by a homeomorphism h of Q keeping \dot{Q} fixed. Let $d = hd^*$. Then the commutativity of the diagram

$$\begin{array}{ccc}
 \dot{Q} \times I & \xrightarrow{d} & Q \\
 \searrow^{d^*} & & \nearrow^h \\
 & Q & \\
 \uparrow^{f \times 1} & \uparrow^f & \\
 & M & \\
 \nearrow^{c^*} & \searrow^{G_1} & \\
 \dot{M} \times I & \xrightarrow{c} & M
 \end{array}$$

and the fact that

$$\begin{aligned}
 \text{im } d \cap \text{im } f &= \text{im } hd^* \cap \text{im } hf \\
 &= h(\text{im } d^* \cap \text{im } f) \\
 &= h(\text{im } fc^*) \\
 &= \text{im } fc,
 \end{aligned}$$

ensure that the collars c, d are compatible with f . The proof of Theorem 5 is complete.

We now prove the crucial lemma for the covering isotopy theorem.

Lemma 8. — *Let M, Q be compact, and let $F : M \times I \rightarrow Q \times I$ be a locally unknotted isotopy keeping \dot{M} fixed. Then there exists $\epsilon > 0$, and a short ambient isotopy $H : Q \times I_\epsilon \rightarrow Q \times I_\epsilon$ of Q that keeps \dot{Q} fixed and covers the beginning of F . In other words the diagram*

$$\begin{array}{ccc}
 Q \times I_\epsilon & \xrightarrow{H} & Q \times I_\epsilon \\
 \uparrow^{F_0 \times 1} & \nearrow^F & \\
 M \times I_\epsilon & &
 \end{array}$$

is commutative.

Proof. — For the convenience of the proof of this lemma we assume that $F_0 = F_1$. For, if not, replace F by F^* , where

$$F^*(x, t) = \begin{cases} F(x, t), & 0 \leq t \leq \frac{1}{2} \\ F(x, 1-t), & \frac{1}{2} \leq t \leq 1. \end{cases}$$

Then, since $F_0^* = F_1^*$, the proof below gives an H covering the beginning of F^* , which is the same as the beginning of F if $\epsilon \leq \frac{1}{2}$.

Therefore assume $F_0 = F_1$. This means that the two proper embeddings $F, F_0 \times 1$ of $M \times I$ in $Q \times I$ agree on the boundary $(M \times I)^\circ$, because F keeps \dot{M} fixed. Choose a collar c of $M \times I$, and then by Theorem 5 choose collars d, d_0 of $Q \times I$ such that c, d are

compatible with F , and c, d_0 are compatible with $F_0 \times I$. We have a commutative diagram of embeddings

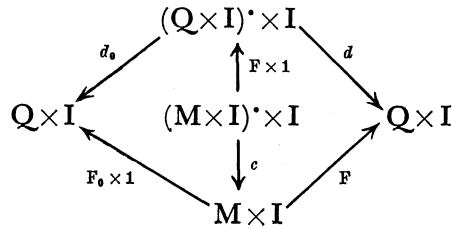

Notice that both the collars d, d_0 map $(Q \times 0) \times 0$ to $Q \times 0$. Therefore $\text{im } d$ contains a neighbourhood of $Q \times 0$ in $Q \times I$, and so contains $Q \times I_\beta$, for some $\beta > 0$. Similarly $d_0 d^{-1}(Q \times I_\beta)$ contains a neighbourhood of $Q \times 0$, and so contains $Q \times I_\alpha$, for some $\alpha, 0 < \alpha \leq \beta$.

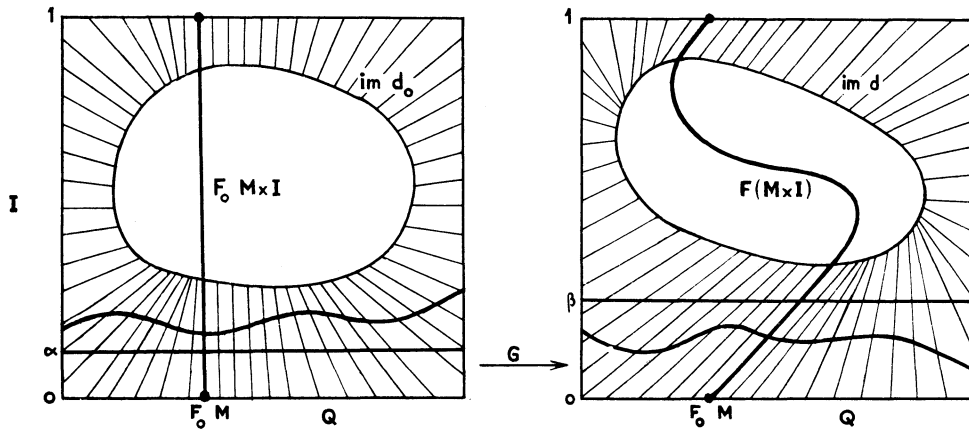

Let

$$G = dd_0^{-1} : Q \times I_\alpha \rightarrow Q \times I_\beta.$$

Then G has the properties

- (i) $G|_{\dot{Q} \times I} = \text{the identity}$, because d, d_0 agree on $(Q \times I)' \times 0$.
- (ii) $G|_{Q \times 0} = \text{the identity}$.
- (iii) G covers the beginning of F in the sense that the diagram

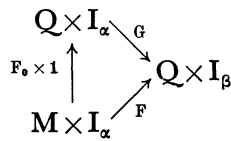

is commutative. For if $x \in M$ and $t \in I_\alpha$ then by compatibility

$$(F_0 x, t) \in \text{im}(F_0 \times I) \cap \text{im } d_0 = \text{im}(F_0 \times I)c.$$

Therefore for some $y \in (M \times I) \cdot \times I$,

$$(F_0 x, t) = (F_0 \times I)cy = d_0(F \times I)y.$$

Therefore

$$\begin{aligned} G(F_0 \times I)(x, t) &= (dd_0^{-1})d_0(F \times I)y \\ &= d(F \times I)y \\ &= Fcy \\ &= F(F_0 \times I)^{-1}(F_0 \times I)cy \\ &= F(F_0 \times I)^{-1}(F_0 x, t) \\ &= F(x, t). \end{aligned}$$

In other words $G(F_0 \times I) = F$, which proves property (iii).

By Lemma 5 there is an ε , $0 < \varepsilon < \alpha$, and an embedding $H : Q \times I_\alpha \rightarrow Q \times I_\beta$ ambient isotopic to G , such that $H|_{Q \times 0} = \text{the identity}$ and H is level preserving in I_ε . Further, since G is already level preserving on $(\dot{Q} \cup F_0 M) \times I_\alpha$, we can by Lemma 5 (iii) choose H to agree with G on this subpolyhedron. In other words, the restriction $H : Q \times I_\varepsilon \rightarrow Q \times I_\varepsilon$ is a short ambient isotopy covering the beginning of F and keeping \dot{Q} fixed.

Proof of Theorem 2, the covering isotopy theorem.

We are given a locally unknotted isotopy $F : M \times I \rightarrow Q \times I$ keeping \dot{M} fixed, and a neighbourhood N of the track left by the isotopy, and we have to cover F by an ambient isotopy H of Q supported by N keeping \dot{Q} fixed. We are given that M is compact, and we first consider the case when Q is also compact and $N = Q$.

If $0 < t < 1$, the definition of locally unknotted isotopy ensures that the restrictions of F to $[0, t]$ and $[t, 1]$ are locally unknotted embeddings, and therefore we can apply Lemma 7 to both sides of the level t , and cover F in the neighbourhood of t . More precisely, for each $t \in I$, there exists a neighbourhood $J^{(t)}$ of t in I , and a level preserving homeomorphism $H^{(t)}$ of $Q \times J^{(t)}$, such that $H^{(t)}$ keeps \dot{Q} fixed, $H^{(t)} = I$, and such that the diagram

$$\begin{array}{ccc} Q \times J^{(t)} & & \\ \uparrow F_t \times 1 & \searrow H^{(t)} & \\ M \times J^{(t)} & \xrightarrow{F} & Q \times J^{(t)} \end{array}$$

is commutative. By compactness we can cover I by a finite number of such intervals $J^{(t)}$. Therefore we can find values t_1, t_2, \dots, t_n and $0 = s_1 < s_2 < \dots < s_{n+1} = 1$, such that for each i , $[s_i, s_{i+1}] \subset J^{(t_i)}$. Write $H^i = H^{(t_i)}$.

We now define H by induction on i , as follows. Define $H_0 = I$. Suppose $H_i : Q \rightarrow Q$ has been defined so that $H_i F_0 = F_t$, for $0 \leq t \leq s_i$. Then define

$$H_i = H_i^i (H_{s_i}^i)^{-1} H_{s_i}, \quad \text{for } s_i \leq t \leq s_{i+1}.$$

Therefore

$$\begin{aligned} H_t F_0 &= H_t^i (H_{s_i}^i)^{-1} H_{s_i} F_0 \\ &= H_t^i (H_{s_i}^i)^{-1} F_{s_i} \\ &= H_t^i F_{t_i} \\ &= F_{t_i}. \end{aligned}$$

At the end of the induction we have H_t defined and $H_t F_0 = F_{t_i}$, all $t \in I$. Moreover H is piecewise linear, because it is composed of a finite number of piecewise linear pieces, and H keeps \dot{Q} fixed because each H^i does. Therefore we have completed the proof for the case when Q is compact and $N = Q$.

We now extend the proof to the general case when Q is not necessarily compact, and $N \subset Q$. We may assume that N is a regular neighbourhood of the track, because any neighbourhood contains a regular neighbourhood. Therefore N is a compact submanifold of Q , because the track is compact. By the compact case F can be covered by an ambient isotopy of N keeping \dot{N} fixed, which can be extended by the identity to an ambient isotopy of Q covering F supported by N and keeping \dot{Q} fixed. The proof of Theorem 2 is complete.

Proof of Addendum 2.1.

The converse of Theorem 2 is trivial, because if F_0 is a locally unknotted embedding, then the constant isotopy $F_0 \times I$ is locally unknotted and locally trivial. If F is covered by H then $F = H(F_0 \times I)$, which is again locally unknotted and locally trivial, because these properties are preserved under the homeomorphism H .

Proof of Addendum 2.2.

Given an ambient isotopy H of \dot{Q} supported by a compact subset X , we have to extend H to an ambient isotopy of Q supported by a given neighbourhood N of X in Q . We cannot deduce the addendum as a corollary to Theorem 2, because the embedding $\dot{Q} \times I \rightarrow Q \times I$ induced by H is not proper, and therefore not an isotopy according to the definition that we are using. However the use of a collar provides an alternative proof as follows.

Without loss of generality we can assume that X is a subpolyhedron, because the support of H is a subpolyhedron contained in X , and that N is a regular neighbourhood of X in Q , because any neighbourhood contains a regular neighbourhood. Therefore N is a compact submanifold of Q . The given ambient isotopy H restricts to X , and then extends by the identity to an ambient isotopy, G say, of \dot{N} keeping $\dot{N} - X$ fixed.

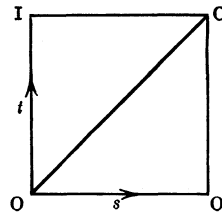

Triangulate the square I^2 as shown, and let $u : I^2 \rightarrow I$ be the simplicial map determined by mapping the vertices to 0 or 1 as shown. Define $G^* : (\dot{N} \times I) \times I \rightarrow (\dot{N} \times I) \times I$ by

$$G^*((x, s), t) = ((G_{u(s,t)}x, s), t).$$

As in the proof of Lemma 6, it follows that G^* is an ambient isotopy of $\dot{N} \times I$ keeping $(\dot{N} \times 1) \cup (\dot{N} - X) \times I$ fixed.

Choose a collar $c : \dot{N} \times I \rightarrow N$ and let H^* be the image of G^* under c . Since G^* keeps $\dot{N} \times 1$ fixed, H^* can be extended by the identity to an ambient isotopy of N ; and since G^* keeps $(\dot{N} - X) \times 0$ fixed, H^* keeps the frontier of N fixed, and so can be further extended to an ambient isotopy H^* of Q supported by N .

Finally we have to show that H^* is an extension of H . If $x \notin X$ then both H and H^* keep x fixed; if $x \in X$ then

$$\begin{aligned} H_t^*x &= (cG_t^*c^{-1})x \\ &= cG_t^*(x, 0) \\ &= c(G_t x, 0) \\ &= G_t x \\ &= H_t x. \end{aligned}$$

The proof of Addendum 2.2 is complete.

Proof of Corollary 2.3.

Corollary 2.3 is concerned with the case when the isotopy F of M in Q does not keep \dot{M} fixed. Let T denote the track of F in Q , which is compact because M is compact. Let $\dot{F} : \dot{M} \times I \rightarrow \dot{Q} \times I$ denote the restriction of F to the boundary, which is locally unknotted because F is. Let X be a regular neighbourhood of the track $T \cap \dot{Q}$ of \dot{F} in \dot{Q} , and let N_0 be a regular neighbourhood of X in Q . Then X, N_0 are compact, and by choosing sufficiently small regular neighbourhoods we can ensure that the given neighbourhood N of T in Q is also a neighbourhood of N_0 .

Now use Theorem 2 to cover \dot{F} by an ambient isotopy of \dot{Q} supported by X , and by Addendum 2.2 extend the latter to an ambient isotopy, G say, of Q supported by N_0 . Then $G^{-1}F$ is an isotopy of M in Q keeping \dot{M} fixed, with track contained in $T \cup N_0$. Since N is a neighbourhood of $T \cup N_0$, we can again use Theorem 2 to cover $G^{-1}F$ by an ambient isotopy, H say, of Q supported by N . Therefore GH covers F and is supported by N .

Proof of Corollary 2.4.

By Corollary 2.3 and the Corollary to Lemma 2.

We now proceed to the proof of Theorem 3.

Lemma 9. — *Any homeomorphism between the boundaries of unknotted ball pairs can be extended to the interiors.*

For do it conewise (see [8, Lemma 2]).

Lemma 10. — *Let (B^q, B^m) and (C^q, C^m) be two unknotted ball pairs. Then any homeomorphisms $h_1: \dot{B}^q \rightarrow \dot{C}^q$ and $h_2: B^m \rightarrow C^m$ that agree on \dot{B}^m can be extended to a homeomorphism $h: B^q \rightarrow C^q$.*

Proof. — By Lemma 9 extend h_1 to $h_3: B^q \rightarrow C^q$, the composition $h_3 h_2^{-1}: C^m \rightarrow C^m$ keeps \dot{C}^m fixed, and, since (C^q, C^m) is unknotted, can be suspended to a homeomorphism $h_4: C^q \rightarrow C^q$ keeping \dot{C}^q fixed. Define $h = h_4^{-1} h_3$. Then $h|_{\dot{B}^q} = h_3|_{\dot{B}^q} = h_1$, and $h|_{B^m} = (h_2 h_3^{-1}) h_3|_{B^m} = h_2$, as desired.

Lemma 11 (*interior linear moves*). — *Let M be a compact m -manifold, and Q a q -manifold, such that $m < q$. Let K be a triangulation of M , and $A = \overline{\text{st}}(v, K)$ a closed vertex star of K contained in the interior of M . Let B be a q -ball in the interior of Q . Suppose $f, g: M \rightarrow Q$ are embeddings such that*

- (i) f, g agree on $M - \dot{A}$,
- (ii) $A = f^{-1}B = g^{-1}B$,
- (iii) (B, fA) and (B, gA) are unknotted ball pairs.

Then f, g are isotopic by two interior linear moves that are linear with respect to K .

Proof. — The geometrical idea of the proof is quite simple: we are faced with two maps $A \rightarrow B$ which may criss-cross each other in the interiors but which agree on the boundary. So we move one onto a nice clean ball in \dot{B} , and then move that back onto the other.

Let Δ^q be the standard q -simplex, Δ^m a face, and Δ^{q-m-1} the opposite face. Let x be the barycentre of Δ^q , and y a point between x and the barycentre of Δ^m (see figure 1). Let $\sigma: \Delta^q \rightarrow \Delta^q$ be the standard interior linear move throwing x to y .

Choose a homeomorphism $h_1: f\dot{A} \rightarrow \dot{\Delta}^m$, and by the unknottedness of the balls concerned, extend h_1 to a homeomorphism $h_2: \dot{B} \rightarrow (x\dot{\Delta}^m \cup \Delta^m)\dot{\Delta}^{q-m-1}$. Extend the composite homeomorphism $h_1 f: \dot{A} \rightarrow \dot{\Delta}^m$ to a homeomorphism $A \rightarrow y\dot{\Delta}^m$ by mapping v to y , and joining linearly; define h_3 so that the diagram

$$\begin{array}{ccc} A & \xrightarrow{\quad} & y\dot{\Delta}^m \\ & \searrow \scriptstyle f & \nearrow \scriptstyle h_3 \\ & fA & \end{array}$$

is commutative. By Lemma 10 extend h_2 and h_3 to

$$h_4: B \rightarrow x\Delta^m\dot{\Delta}^{q-m-1}.$$

Let $C = h_2^{-1}(x\dot{\Delta}^m\dot{\Delta}^{q-m-1})$, which is a $(q-1)$ -ball facing B . We now construct a q -ball N contained in Q , meeting B in the common face C , and meeting fM in $f\dot{A}$. We can either construct N explicitly, or else observe that N is a regular neighbourhood of $C \bmod (\dot{C} \cup f(M - \dot{A}))$ in $Q - \dot{B}$ that meets the boundary regularly, and appeal to the existence theorem [4, Theorem 1] for such relative regular neighbourhoods (using

that C is link-collapsible on \dot{C}). An explicit construction for N is as follows : let K be a triangulation of $Q - \dot{B}$ containing C and $f(M - \dot{A})$ as subcomplexes. Then K is a manifold since B lies in the interior of M . Let K'' be the second barycentric derived complex of K . Let N be the simplicial neighbourhood of \dot{C} in K'' , that is to say the union of all closed simplexes of K'' meeting \dot{C} . By construction N has the desired intersections with B and fM . Finally N is a ball because by [4, Theorem 1] N is a manifold that collapses to C , and so N is collapsible; but any collapsible manifold is a ball.

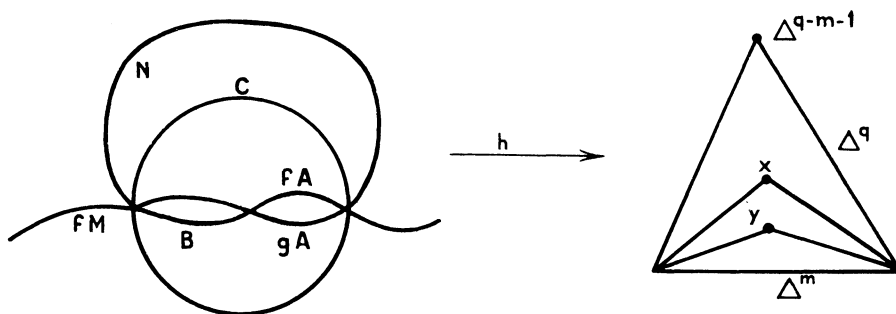

Since C is a face of N , we can extend $h_2|_C : C \rightarrow x\dot{\Delta}^m\dot{\Delta}^{q-m-1}$ to a homeomorphism

$$h_5 : N \rightarrow x\dot{\Delta}^m\dot{\Delta}^{q-m-1}.$$

Therefore h_4 and h_5 together define a homeomorphism $h : B \cup N \rightarrow \Delta^q$. Now define an embedding $e : M \rightarrow Q$ by

$$\begin{aligned} e|M - \dot{A} &= f|M - \dot{A} \\ e|A &= h^{-1}\sigma^{-1}h(f|A). \end{aligned}$$

Since $f^{-1}(B \cup N) = A$, the move from e to f is linear with respect to K . But the construction of e depended only on k_2 , which in turn depended only on \dot{B} and $f|\dot{A}$. By hypothesis $f|\dot{A} = g|\dot{A}$, and so e depends symmetrically on f and g . Therefore there is also a linear move from e to g , and so f, g are isotopic by two linear moves.

Lemma 12 (boundary linear moves). — Let M be a compact m -manifold, and Q a q -manifold, where $m < q$. Let K be a triangulation of M and let $A = \overline{\text{st}}(v, K)$, where v is a boundary vertex of K . Let B be a q -ball in Q , that meets the boundary in a $(q-1)$ -ball. Suppose $f, g : M \rightarrow Q$ are proper embeddings such that

- (i) f, g agree on $\overline{M - A}$,
- (ii) $A = f^{-1}B = g^{-1}B$,
- (iii) (B, fA) and (B, gA) are two unknotted ball pairs, that meet the boundary \dot{Q} in an unknotted face. Then f, g are isotopic by two boundary linear moves, that are linear with respect to K .

Proof. — Denote by a superscript star the restriction of everything to the boundary : $M^* = \dot{M}, f^* = f|\dot{M} : M^* \rightarrow Q^*, A^* = A \cap M^*$, etc. Since (B^*, fA^*) is an unknotted ball pair, we can find, by the proof of Lemma 11, a ball N^* , a homeomorphism $h^* : B^* \cup N^* \rightarrow \Delta^{q-1}$,

and an embedding $e^* : M^* \rightarrow Q^*$ such that e^*, f^* differ by the interior linear move determined by the standard interior linear move $\sigma^* : \Delta^{q-1} \rightarrow \Delta^{q-1}$.

Regard $\Delta^q = V\Delta^{q-1}$ as the cone on Δ^{q-1} with vertex V . Let $\sigma : \Delta^q \rightarrow \Delta^q$ be the standard boundary move induced by σ^* . We want to find $e : M \rightarrow Q$ such that e, f differ by the boundary linear move determined by σ .

Since (B^*, fA^*) is an unknotted face of (B, fA) , the complementary face is also unknotted (see [4, Corollary 4]). Therefore using Lemma 9 twice, extend $h^*|_{B^*}$ to a homeomorphism onto the cone pair

$$h : (B, fA) \rightarrow (V(h^*B^*), V(h^*fA^*)).$$

Let

$$N_0 = N^* \cup h^{-1}(V(h^*(B^* \cap N^*)))$$

which is a $(q-1)$ -ball, because it is the union of two balls meeting in the common face $B^* \cap N^*$. Let N be a regular neighbourhood of $N_0 \bmod (\dot{N}_0 \cup f(\overline{M-A}))$ in $\overline{Q-B}$ that meets the boundary regularly. Then N is a q -ball meeting $N^* \cup B$ in the face N_0 , and so we can extend the embeddings $h^* : N^* \rightarrow \Delta^q$ and $h : B \rightarrow \Delta^q$ to a homeomorphism

$$h : B \cup N \rightarrow \Delta^q.$$

Define $e : M \rightarrow Q$ by

$$\begin{aligned} e|_{\overline{M-A}} &= f|_{\overline{M-A}} \\ e|_A &= h^{-1}\sigma^{-1}h(f|_A). \end{aligned}$$

Then Lemma 12 follows as in the proof of Lemma 11.

Proof of Theorem 3.

We are given proper embeddings $f, g : M \rightarrow Q$ of codimension > 0 , that are locally unknotted and ambient isotopic. We have to show that they are isotopic by linear moves. Since M is compact, we can assume that the ambient isotopy has compact support by Addendum 1.2; therefore by restricting attention to a regular neighbourhood of this support, we can assume that Q is also compact.

First consider the case when M is closed. Choose triangulations of M, Q — call them by the same names — such that $f : M \rightarrow Q$ is simplicial and the simplicial neighbourhood of fM in Q lies in the interior of Q . Now apply the machinery of the proof of Theorem 1. We obtain a sequence k_0, k_1, \dots, k_n of homeomorphisms of Q , such that $k_0 = 1, k_n f = g$, and, for each i , k_{i-1} and k_i agree outside some vertex star of Q . Let $f_i = k_i f$. Fix i for the moment. Suppose k_{i-1} and k_i agree outside $\text{st}(u, Q)$. If $u \notin fM$ then $f_{i-1} = f_i$. If $u \in fM$, let $v = f^{-1}u \in M$, and let $A = \overline{\text{st}(v, M)}, B = k_i(\overline{\text{st}(u, Q)})$. Then $A = f_{i-1}^{-1}B = f_i^{-1}B$, and the ball pairs $(B, f_{i-1}A), (B, f_iA)$ are unknotted since f is locally unknotted. Therefore we have precisely the situation of Lemma 11, and so f_{i-1}, f_i are isotopic by two interior linear moves. Therefore f, g are isotopic by interior linear moves.

Now consider the case when M is bounded. As before choose triangulations M, Q such that f is simplicial, and let M', Q' be the barycentric first derived complexes of M, Q . Apply the above machinery to Q' . Fix i , and suppose that k_{i-1}, k_i agree outside $\overline{\text{st}}(u', Q')$, where $u' \in fM'$. There are two possibilities according as to whether or not $\overline{\text{st}}(u', Q')$ meets the boundary \dot{Q} . If not, proceed as above and use Lemma 11. If it does meet the boundary, then $\text{st}(u', Q') \subset \text{st}(u, Q)$, for some $u \in f\dot{M}$. Reverting to stars in the underived complexes M, Q , we are then in the situation of Lemma 12, and so f_{i-1}, f_i are isotopic by two boundary linear moves. Therefore f, g are isotopic by linear moves. The proof of Theorem 3 is complete.

Proof of Corollary 3.1.

By Corollary 1.3, Corollary 2.4 and Theorem 3.

Proof of Addendum 3.2.

M is closed, and we are given a specific triangulation K of M . Choose a subdivision K_1 of K and a triangulation L_1 of Q such that $f: K_1 \rightarrow L_1$ is simplicial. Let K_2, L_2 be the second barycentric derived complexes of K_1, L_1 . Then $f: K_2 \rightarrow L_2$ is also simplicial.

In the above proof of the closed case in Theorem 3 use K_2, L_2 to construct the sequence k_0, k_1, \dots, k_n of homeomorphisms of Q , and embeddings $f_i = k_i f: M \rightarrow Q$. Fix i for the moment. The proof of Theorem 3 showed that f_{i-1}, f_i differ by two moves linear with respect to K_2 ; we want them linear with respect to K , which is not immediately obvious because the simplexes of K may be large compared with those of K_2 ; whereas the vertex stars of K_2 are embedded locally, those of K may be spread globally over Q .

Let u_2 be the vertex of L_2 such that k_{i-1}, k_i agree outside $\text{st}(u_2, L_2)$. Assume $u_2 \in fM$, otherwise $f_{i-1} = f_i$ and the problem is trivial. Therefore we can define $v_2 = f^{-1}u_2 \in K_2$, $A_2 = \overline{\text{st}}(v_2, K_2)$, and $B_2 = k_i(\overline{\text{st}}(u_2, L_2))$. Then $A_2 = f_{i-1}^{-1}B_2 = f_i^{-1}B_2$.

Now since L_2 is the second derived complex of L_1 , every closed vertex star of L_2 is contained in some open vertex star of L_1 .

Therefore $\overline{\text{st}}(u_2, L_2) \subset \text{st}(u_1, L_1)$, for some $u_1 \in L_1$. Then $u_1 \in fM$, because $\text{st}(u_1, L_1)$ meets fM , and so there exists $v_1 = f^{-1}u_1 \in K_1$. Let $A_1 = \overline{\text{st}}(v_1, K_1)$ and $B_1 = k_i(\overline{\text{st}}(u_1, L_1))$. Then $A_1 = f_{i-1}^{-1}B_1 = f_i^{-1}B_1$, because $B_1 \supset B_2$. Also $(B_1, f_{i-1}A_1), (B_1, f_iA_1)$ are unknotted ball pairs by the local unknottedness of f .

Since M is closed, v_1 is an interior vertex of K_1 , and so u_1 is an interior vertex of L_1 , because f is proper. By our choice of $u_1, B_2 \subset \dot{B}_1$, and therefore

$$A_2 = f_i^{-1}B_2 \subset f_i^{-1}\dot{B}_1 = \dot{A}_1.$$

Since K_1 is a subdivision of K , $\text{st}(v_1, K_1) \subset \text{st}(v, K)$, for some vertex $v \in K$. Let $A = \overline{\text{st}}(v, K)$. Then $A_1 \subset A$. Therefore both the balls A, A_1 are regular neighbourhoods

of A_2 in M . Therefore there is an ambient isotopy, G say, of M moving A_1 onto A and keeping A_2 fixed (see [4, Theorem 3]). The composition

$$(M - \mathring{A}_2) \times I \xrightarrow{G} (M - \mathring{A}_2) \times I \xrightarrow{f_i \times 1} (Q - \mathring{B}_2) \times I$$

is an isotopy of $M - \mathring{A}_2$ in $Q - \mathring{B}_2$ keeping A_2 fixed, and so by Theorem 2 can be covered by an ambient isotopy, H say, of $Q - \mathring{B}_2$ keeping \mathring{B}_2 fixed. Extend H by the identity to an ambient isotopy H of Q keeping B_2 fixed. Let $B = H_1 B_1$. Then $B \supset B_2$, and so

$$A = f_{i-1}^{-1} B = f_i^{-1} B,$$

because the same formulae hold for A_1, B_1 and the homeomorphism H_1 throws $B_1, f_{i-1} A_1, f_i A_1$ to $B, f_{i-1} A, f_i A$, respectively. Similarly $(B, f_{i-1} A), (B, f_i A)$ are unknotted ball pairs, because the same is true for A_1 and B_1 . Finally f_{i-1}, f_i agree on $M - \mathring{A}$ because by construction they agree on $M - \mathring{A}_2$, and $A_2 \subset A$. Therefore by Lemma 11, f_{i-1}, f_i are isotopic by two moves linear with respect to K . Consequently f, g are isotopic by moves linear with respect to K , and the proof of Addendum 3.2 is complete.

REFERENCES

- [1] J. W. ALEXANDER, On the deformation of an n -cell, *Proc. Nat. Acad. Sci. U.S.A.*, 9 (1923), 406-407.
- [2] J. F. P. HUDSON, *Collaring theorems* (to appear).
- [3] J. F. P. HUDSON, *Covering isotopies* (to appear).
- [4] J. F. P. HUDSON and E. C. ZEEMAN, *On regular neighbourhoods* (to appear).
- [5] N. H. KUIPER (to appear).
- [6] B. MAZUR, *The definition of equivalence of combinatorial embeddings*, *Inst. des Hautes Études Sci.*, 3 (1959), 97-109.
- [7] D. E. SANDERSON, Isotopy in manifolds, *Topology of 3-manifolds*, Ed. M. K. Fort Jr., Prentice Hall, 1962.
- [8] E. C. ZEEMAN, Unknotting combinatorial balls, *Annals of Math.* (to appear).

Institut des Hautes Études Scientifiques, Paris.

Reçu le 15 juin 1963.